



**PERFORMER SERIES CARBURETOR  
ELECTRIC CHOKE KIT  
CATALOG NUMBER:#1478  
For Edelbrock #1405 & #1407 carburetors  
INSTALLATION INSTRUCTIONS**

The enclosed electric choke kit is designed to replace the existing manual choke on Edelbrock *Performer Series* carburetors #1405 and #1407. Please follow the instructions closely to ensure a proper installation. For technical questions call: **1-800-416-8628**.

**INSTALLATION KIT CONTENTS**

- |                                     |                                  |                       |
|-------------------------------------|----------------------------------|-----------------------|
| 1- Choke Piston Housing             | 1- Choke Cap Gasket              | 3- Choke Cap Retainer |
| 1- Connecting Rod                   | 1- Hair Clip Retainer            | 1- Shaft Subassembly  |
| 1- Thermostatic Coil Assembly w/Cap | 3- Choke Housing Attaching Screw | 1- 1/4" AN Washer     |
| 1- Choke Cable Lever                | 1- Choke Ground Wire (black)     | 1- Lever (14-555)     |
| 1- Baffle Plate                     | 3- Choke Cap Screw               |                       |
| 1- Choke Piston Housing Seal        | 1- Choke Positive Wire (red)     |                       |

**CHOKE INSTALLATION**

- Remove the carburetor from the engine by disconnecting all linkages and lines. Use the original carburetor Installation Instructions as a guide.
- Remove the manual choke cable clamp bracket (Figure 1) by removing the airhorn screw. Re-tighten the airhorn screw after the bracket has been removed.

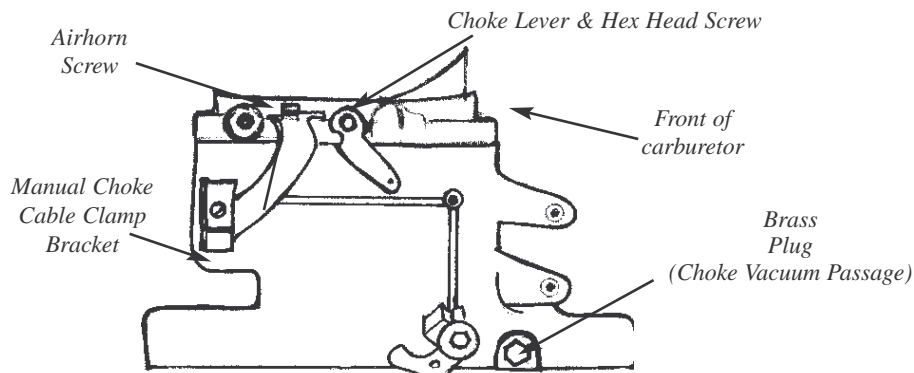
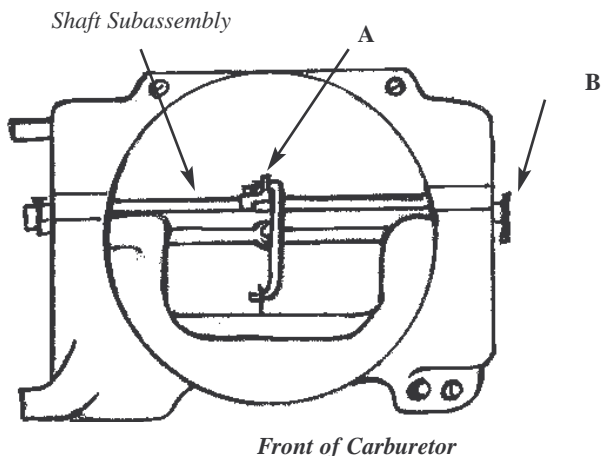

FIGURE 1

- Remove the choke cable lever hex head screw and the choke cable lever (Figure 1).
- Remove the screw A (Figure 3) that holds the choke linkage to the shaft subassembly.
- Remove hair clip B and pull the shaft subassembly out of the airhorn.
- Place the new lever #14-555 on the new shaft and slide this subassembly into the airhorn. The lever should be located on the shaft using Figure 7 as a guide. Using the hair clip, reattach the fast idle linkage rod D.



Front of Carburetor  
FIGURE 3

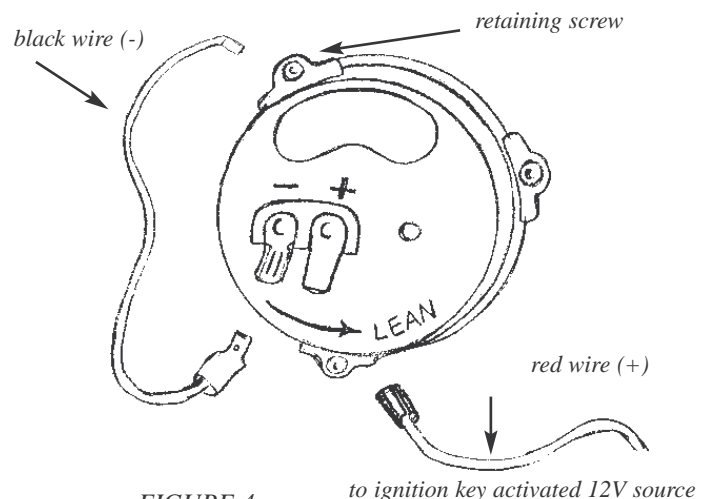

FIGURE 4

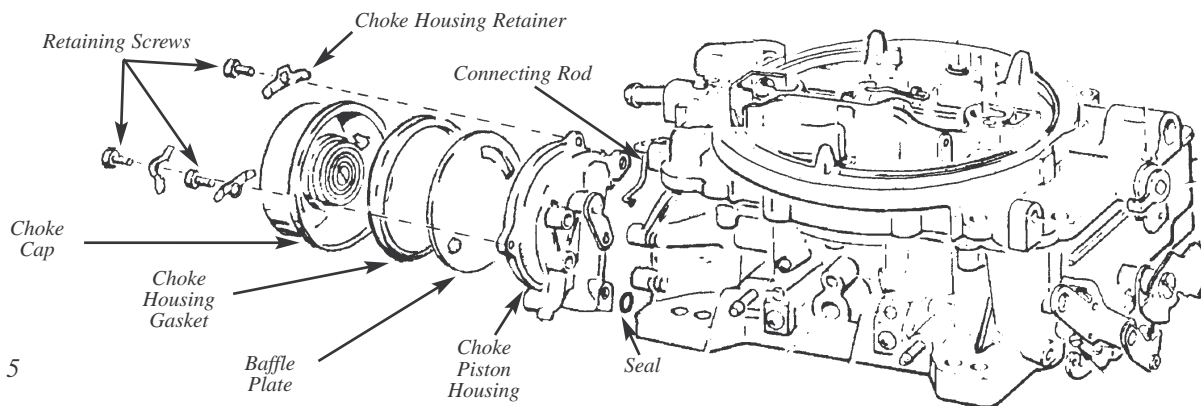

FIGURE 5

7. Reinstall screw A and related linkage as shown in Figure 3. **WARNING:** This procedure can only be done once as the shaft threads are not reusable. Be very careful not to strip out the screw by overtightening. Stop turning when the screw head contacts the bracket.
8. Place the 1/4" AN washer from the kit on the protruding end of the shaft. Install the new electric choke lever using the hex head screw (Figure 1). Ensure choke valve and linkages work freely. It may be necessary to remove the aforementioned 1/4" AN washer if the shaft is binding.
9. Remove the brass plug (Figure 1) from the choke vacuum passage using pliers. Blow compressed air through the passage to ensure it is not blocked.
10. Place the connecting rod into the keyed slot of the choke housing lever (Figure 5). Place the choke piston housing seal into the cast recess of the choke housing.
11. Install the choke piston housing on the carburetor using the three

- self-tapping #20 Torx screws.
12. Place the unattached end of the connecting rod through the hole in choke cable lever and secure it with a hair clip retainer (supplied).
13. Install the baffle plate with the indentation facing the carburetor (Figure 5). Install the choke cap and cap gasket using the supplied retainers and screws. When doing so, attach the black ground wire by placing the eyelet end of the wire between the designated screw and retainer (Figure 4).
14. Connect the clip end of the black ground wire to the negative (-) spade terminal on the choke housing (Figure 4).
15. Connect the red wire spade terminal to the positive (+) terminal on choke housing (Figure 4). Connect the other end of the red wire to an ignition key activated 12 volt source. Ensure this source maintains 12 volts with the engine running.

DO NOT ATTACH TO COIL.

### CHOKE ADJUSTMENT

To adjust the choke piston linkage (Figure 6) open the choke valve and insert a .026" wire (commonly found in hobby shops), with a 90 degree bend 1/8" from the end, between the top of the slot in the choke piston cylinder and the bottom of the slot in the piston. Hold the wire in position and close the choke valve by pressing on piston lever A until resistance is felt. The dimension C should be .100" between the top edge of the choke valve and the air horn. To adjust, bend rod B.

To adjust the fast idle linkage (Figure 7) place the fast idle screw A between the two notches on the cam. Close the choke valve as far as possible without forcing it. The dimension C should be 3/64" between the choke valve and air horn. To adjust this dimension, bend rod D.

Fast idle may be adjusted to manufacturers specifications (usually 1500 rpm) during normal choke cold operation. The fast idle screw A can be adjusted with engine off and throttle held open to allow screw head access. Recheck fast idle speed after each adjustment.

The length of time during which the choke will stay closed is determined by the position of the choke cap. As the choke cap is turned clockwise the choke will stay closed longer. To properly set the choke turn the choke cap to the leanest notch on the choke housing, tighten the choke housing retaining screws, and run the engine until normal operating temperature is reached. With the engine running, slowly turn the choke cap clockwise until the choke valve begins to close. Now turn the choke housing one notch counterclockwise (LEAN) and tighten the choke housing retaining screws. Periodic readjustment of the choke will be required as the temperature changes throughout the year. After each adjustment verify that the choke valve opens fully after the engine is warm.

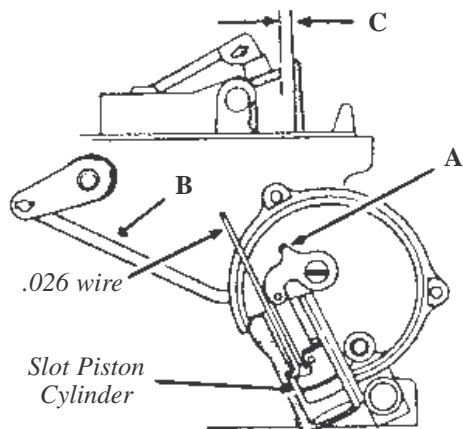

FIGURE 6

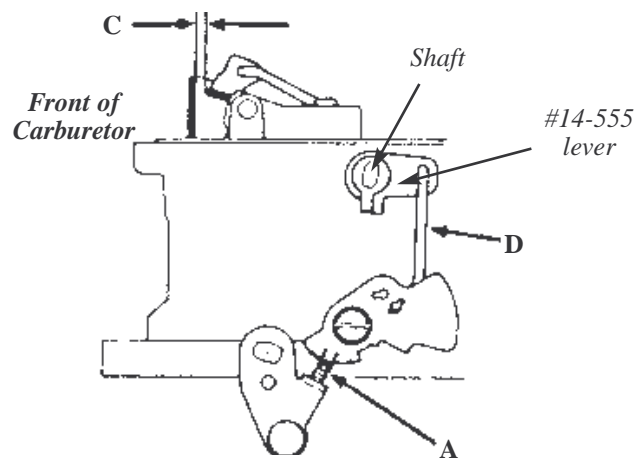

FIGURE 7