



## INSTALLATION INSTRUCTIONS FOR PART 99-3043

### APPLICATIONS

See application list inside

# Chevrolet/GMC/Isuzu/Oldsmobile 1994-1997 99-3043

### KIT FEATURES

- DIN and ISO DIN unit provisions
- Factory pocket provisions



### KIT COMPONENTS

- A) Radio housing • B) Faceplate • C) Shaft supports • D) (4) 5 mm Flat head screws
- E) (2) Carriage bolts • F) (2) Keps nuts • G) (2) #6 Self tapping screws • H) ISO DIN brackets

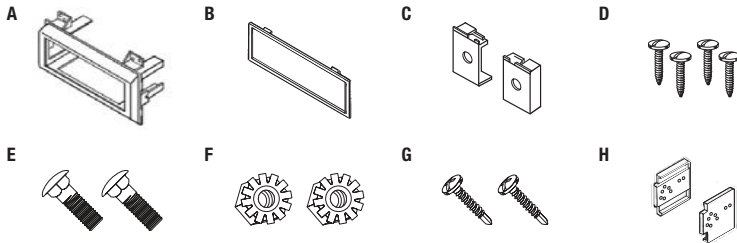

### WIRING & ANTENNA CONNECTIONS (sold separately)

Wiring Harness:

- 70-1858 - GM harness for select 1988-2002

Antenna Adapter:

- 40-GM10 - GM adaptor for select 1988-2006

### TOOLS REQUIRED

- Cutting tool • Phillips screwdriver • Socket wrench

**CAUTION:** Metra recommends disconnecting the negative battery terminal before beginning any installation. All accessories, switches, and especially air bag indicator lights must be plugged in before reconnecting the battery or cycling the ignition.

**NOTE:** Refer to the instructions included with the aftermarket radio.

REV 10/5/2012 INST99-3043

## Applications

<b>Chevrolet</b>	
Blazer .....	1995-1997
S-10 Pickup .....	1994-1997
<b>GMC</b>	
Jimmy .....	1995-1997
Sonoma .....	1994-1997
<b>Isuzu</b>	
Hombre .....	1996-1997
<b>Oldsmobile</b>	
Bravada .....	1995-1997

## Table of Contents

<b>Dash Disassembly</b>	
– Chevrolet Blazer 1995-1997 .....	2
– Chevrolet S-10 Pickup 1994-1997 .....	2
– GMC Jimmy 1995-1997 .....	2
– GMC Sonoma 1994-1997 .....	2
– Isuzu Hombre 1996-1997 .....	2
– Oldsmobile Bravada 1995-1997 .....	2
<b>Kit Assembly</b>	
– DIN head unit provision .....	3
– ISO DIN head unit provision .....	3

## All Vehicles

1. Remove (2) screws above the speedometer cluster. (Figure A)
  2. Remove the ashtray and (1) screw exposed in the ashtray cavity.
  3. Remove (2) screws from the lower steering column trim bezel and remove the bezel. (Figure A)
  4. Unclip the dash trim bezel, disconnect the light switch wiring, and remove the bezel.
  5. Remove (4) screws securing the climate control panel and remove the panel. (Figure A)
  6. Remove (4) screws securing the factory head unit/pocket assembly and disconnect the wiring.
  7. Remove the pocket from the factory head unit and slide the side tabs on the radio housing between the mounting tabs on the pocket. (Figure B)
  8. Mount the pocket to the radio housing with (2) carriage bolts and (2) nuts supplied. (Figure C)
- Continue to kit assembly*

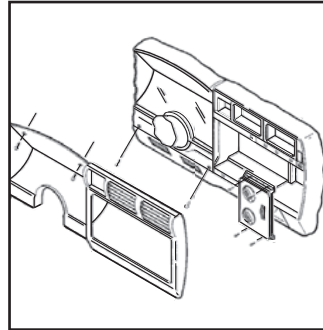

(Figure A)

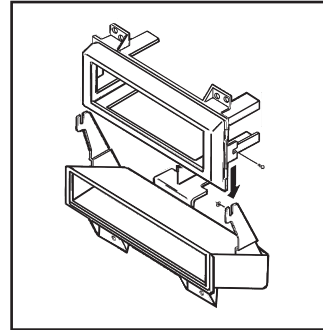

(Figure B)

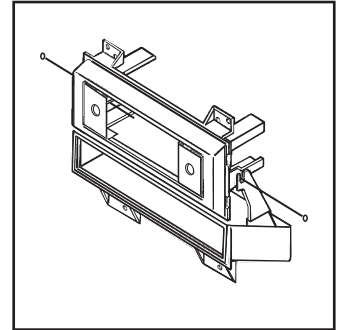

(Figure C)



## Kit Assembly

### DIN head units provision

1. Slide the DIN cage into the kit and secure by bending the metal locking tabs down. (Figure A)
2. Slide the aftermarket head unit into the cage until secure. (Figure A)
3. Locate the factory wiring harness in the dash. Metra recommends using the proper mating adapter from Metra or AXCESS. Re-connect the negative battery terminal and test the unit for proper operation.

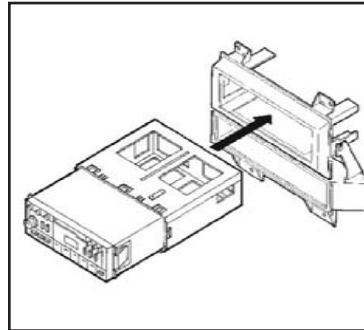

(Figure A)

4. Mount the head unit/kit assembly to the sub-dash with (4) screws previously removed. (Figure B)
5. Reassemble dash in reverse order of disassembly.

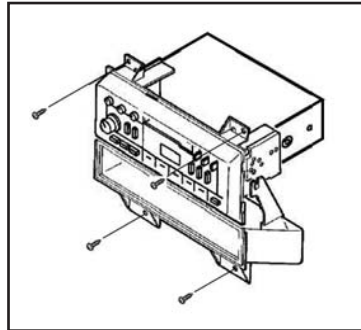

(Figure B)

### ISO DIN head unit provision

1. Snap the faceplate into the radio housing. (Figure A)
2. Slide the aftermarket head unit into the back of the kit. (Figure A)
3. Slide the ISO-DIN brackets onto the housing legs and align the holes in the brackets with the holes in the unit. (Figure A)
4. Mount the brackets to the unit with (4) 5 mm flat head screws supplied "A". (Figure A)
5. Mount the brackets to the top of the

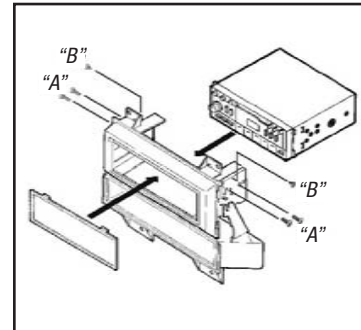

(Figure A)

housing legs with (2) #6 self-tapping screws "B". (Figure A)

6. Locate the factory wiring harness in the dash. Metra recommends using the proper mating adapter from Metra or AXCESS. Re-connect the negative battery terminal and test the unit for proper operation.
7. Mount the head unit/kit assembly to the sub-dash with (4) screws previously removed. (Figure B)
8. Reassemble dash in reverse order of disassembly.

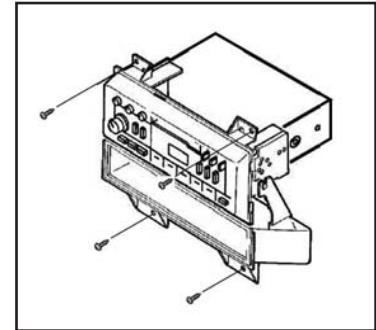

(Figure B)



## INSTALLATION INSTRUCTIONS FOR PART 99-3043

REV. 10/5/2012 INST99-3043



### KNOWLEDGE IS POWER

Enhance your installation and fabrication skills by enrolling in the most recognized and respected mobile electronics school in our industry. Log onto [www.installerinstitute.com](http://www.installerinstitute.com) or call 800-354-6782 for more information and take steps toward a better tomorrow.



**Metra recommends MECP  
certified technicians**