



Carburetor TPS kit

P/N 534-202

INSTALLATION INSTRUCTIONS

INTRODUCTION

Congratulations on your purchase of a Carbureted TPS kit. Holley Performance Products has written this manual for the installation of the TPS kit. **This TPS kit is designed to be used on electric choke equipped Holley carburetors only. It is intended to be used for data acquisition or for use with an electronic transmission. Please refer to the instructions for your data acquisition or transmission control module for wiring and voltage information.** Please read all **WARNINGS** and **NOTES**. They contain valuable information that can save you time and money. Should you need information or parts assistance, please do not return the unit to the store without first contacting Holley technical service at 1-270-781-9741, Monday - Friday, 8 a.m. to 5 p.m. CST. Please have the part number on hand of the product you purchased when you call technical service.

WARNING! To preserve the warranty, instructions must be read and followed thoroughly and completely, before and during installation.

NOTE: Holley Performance Products cannot and will not be responsible for any alleged or actual engine, transmission, or other damage or conditions resulting from misapplication of the TPS kit described.

NOTE: Prior to and after installing your new TPS kit, manually operate the throttle lever to check for binding or other malfunctions.

NOTE: This installation should be done OFF the vehicle.

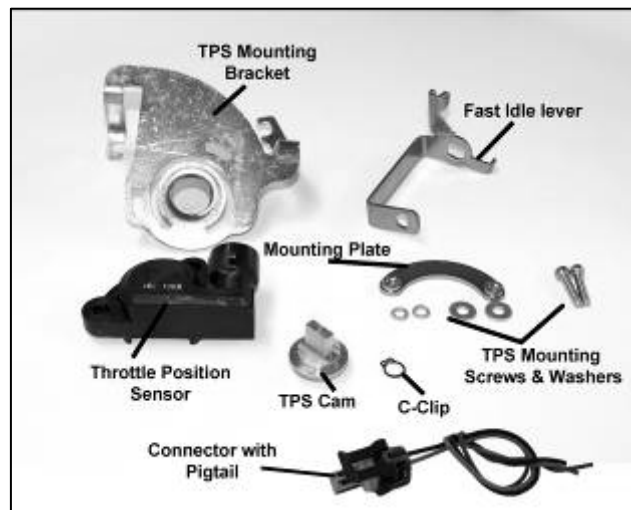

Kit Contents

CARBURETOR REMOVAL:

1. Remove the air cleaner, exercising care to carefully detach any vacuum lines to the air cleaner and marking them so they can be reassembled to the air cleaner in the same manner.
2. Remove the carburetor by the following procedure:
 - A. Carefully disconnect the fuel line.

WARNING: Carefully protect the open end of the fuel lines, so that no foreign particles can enter. Wrap the end of the fuel line with a clean lint-free cloth.

- B. Disconnect and mark all the vacuum lines to the carburetor.
- C. Disconnect the PCV hose.
- D. Disconnect the choke positive wire.
- E. Disconnect and remove the throttle linkage and automatic kickdown linkage. **SAVE ALL RETAINING CLIPS.**
- F. Unbolt and remove the carburetor from the manifold.

CHOKE REMOVAL:

1. Mark the choke index position for easy reassembly, Remove the choke cap by removing the three choke cap clamp screws and set aside. (Figure 1) Remove the choke cap gasket and set aside.



Figure 1

2. Remove the retaining clip from the choke rod to choke shaft and set aside. (Figure 2)



Figure 2

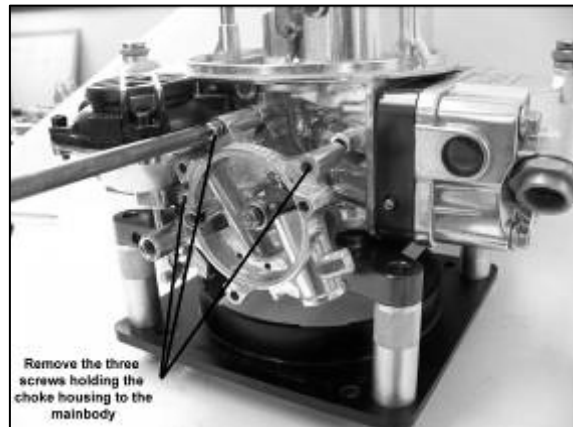

Figure 3

3. Remove the choke housing assembly from the carburetor main body by removing the three Phillips head screws and set aside. (Figure 3)

NOTE: There is a cork gasket on the backside of the choke that seals a vacuum passage to the main body. Do not discard as it will be reused.

4. Remove the Phillips head screw from the end of the primary throttle shaft as shown in figure 4. Remove the fast idle lever from the primary throttle shaft.

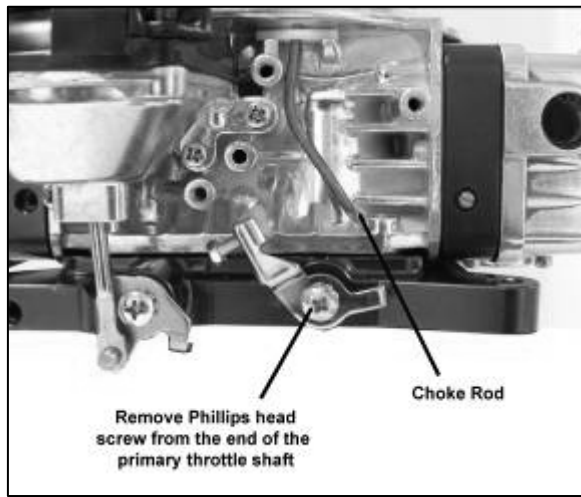

Figure 4



Figure 5

5. Remove the fast idle screw and retaining clip from the original fast idle lever and install on the new fast idle lever from the kit. Make sure you count the threads on the screw and install in the same position. (Figure 5)

INSTALLATION:

1. Install the TPS cam into the D-slot of the new fast idle cam and retain with the supplied C-clip. (Figure 6)
2. Install the fast idle lever and cam assembly onto the primary throttle shaft and retain with the Phillips head screw removed in step 4 of disassembly. Torque to 8 in/lbs minimum. (Figure 7)

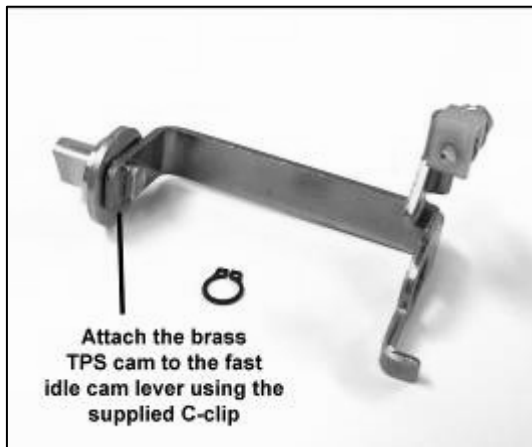

Figure 6



Figure 7

3. Re-attach the choke rod to the choke lever on the back of the choke housing and install the retaining clip from step 2 in disassembly. Make sure the choke rod is below the red plastic fast idle cam as shown in figure 8.



Figure 8

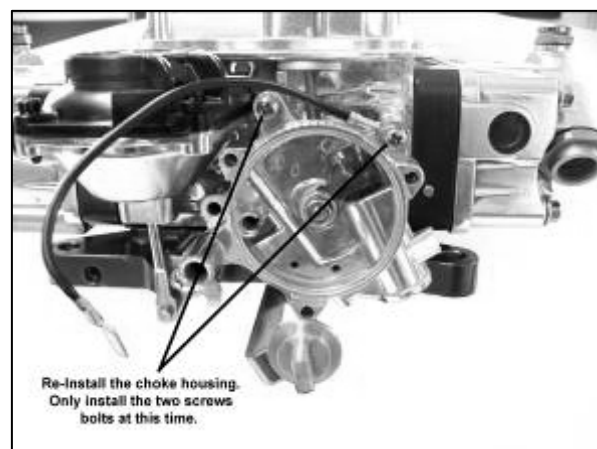

Figure 9

4. Make sure the cork gasket is still in place in the choke housing or main body. If it is not, attach it to the vacuum passage on the back of the choke housing. Re-attach the choke housing to the main body using only the top two screws as shown in figure 9 making sure the choke ground wire is behind the top right screw. . The third screw will be installed in a later step. It will help to open the throttle slightly to pull the fast idle lever away from the fast idle cam assembly.
5. Manually operate the choke plate by moving the bi-metal pick-up lever on the front of the choke housing. The choke plate should move freely. If not, check the choke linkage to make sure there is no binding.
6. Install the choke cap gasket back onto the housing.

IMPORTANT: When installing the choke cap, be sure the bi-metal pick-up lever (in the housing) fits into the loop on the bi-metal spring. Check this by turning the choke cap in both directions. The choke plate should open when rotated clockwise, and it should close when rotated counter-clockwise.

7. Install the electric choke cap and retaining ring. Install only the LH and bottom screws in this step. The RH screw will be installed later. (See figure 10) Install the ring so it bows outward from the choke cap. Tighten it enough to hold the cap in place, but allow it to be rotated.
8. Rotate the choke cap until the mark on the cap aligns with the index on the choke housing. Tighten the retaining screws so the cap cannot rotate.

NOTE: How to set the choke to index. Align the notch in the black plastic choke cap with the longest line on the choke housing. This is usually the line in the middle on the choke housing.

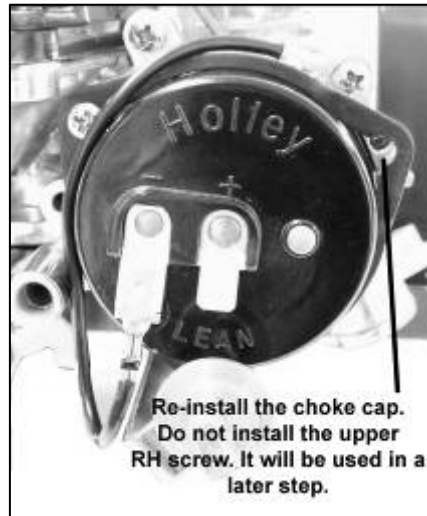

Figure 10

9. Install the TPS bracket to the choke housing using the two screws left out in steps 4 and 7. Make sure the TPS cam seats into the round hole in the bracket. If the TPS cam does not seat properly, some minor tweaking of the fast idle lever may be needed. (See Figure 11)



Figure 11

IMPORTANT: Inspect the choke wires and terminals on the choke cap to ensure there is adequate clearance between the choke cap and the back of the TPS bracket. If there is not enough clearance, adjust the wires and tie back with a zip tie or equivalent to ensure proper clearance is achieved.

10. Install the Throttle Position Sensor to the bracket using the supplied screws, flat washers, lock washers, and mounting plate. The TPS bracket is designed so the TPS can be adjusted to obtain the proper voltage needed for the application it is being utilized for. (See figure 12)

NOTE: Prior to and after installing your new TPS kit, manually operate the throttle lever to check for binding or other malfunctions.

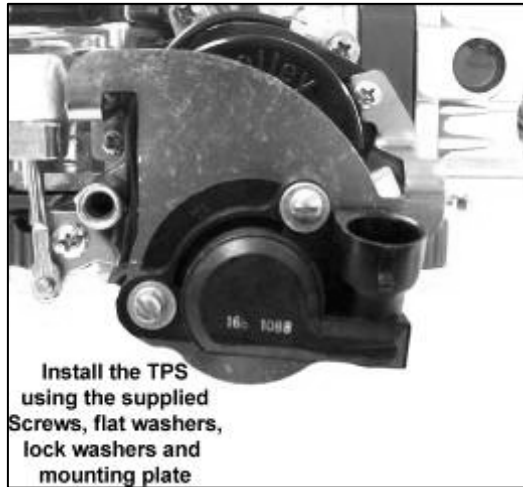

Figure 12

11. A TPS connector with pigtail is included in the kit. Figure 13 shows the pin out for the Throttle Position Sensor. The wire colors on the connector with pigtail are as follows:
 - Blue = Output wire
 - Black = Ground
 - Grey = +5 Volt reference

IMPORTANT: This TPS kit is intended to be used with data acquisition or for use with an electronic transmission. Please refer to the instructions for your data acquisition or transmission control module for wiring and voltage output information.

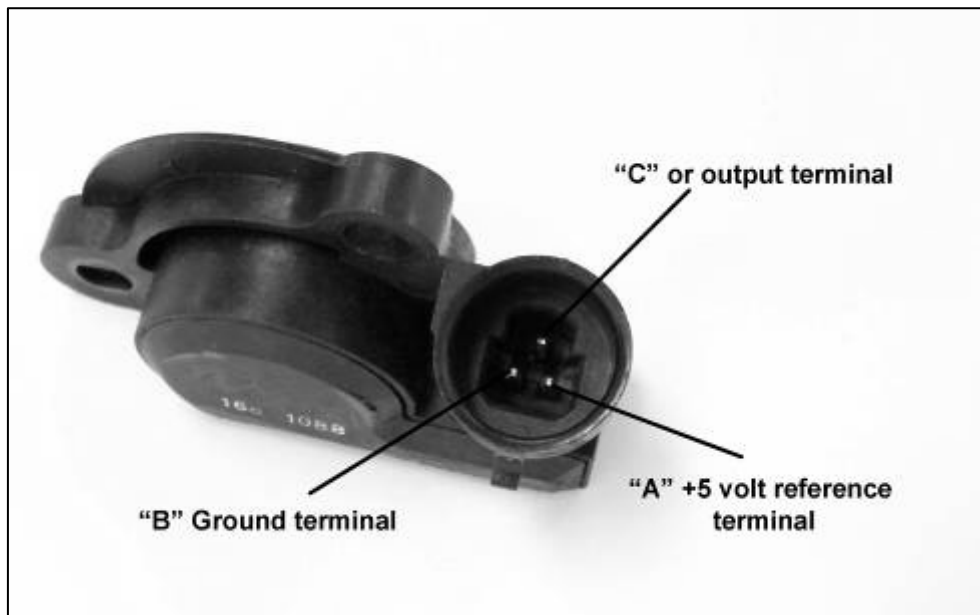

Figure 13

**Holley Technical Support
1801 Russellville Rd
Bowling Green, KY 42101**

**Phone: 1-270-781-9741
Toll-Free Phone: 1-866-GOHOLLEY
Fax: 1-270-781-9772**

**For online help, please refer to the Tech Service
section of our website: www.holley.com**