

MSD INSTALLATION INSTRUCTIONS

Throttle Cable Bracket, for OEM Cables, PN 2707 for use on the Atomic AirForce Intake Manifold

Parts Included:

- 2 - 5mm washers
- 2 - 5mm nylock nuts
- 1 - #12 Mil Spec washer
- 1 - 6mm x 35 socket head cap screw
- 1 - Spacer

Parts Required (Supplied with Manifold)

- 2 - M6 Self-Threading Screws
- 1 - M6x1x30 Socket Head Cap Screw
- 1 - M6 Square Nut

When adapting a cable driven throttle body to an Atomic AirForce Intake Manifold, this Bracket Kit will provide a mount for an OEM style throttle cable assembly.

Note: If using an aftermarket cable assembly, Bracket Kit PN 2708 is required.

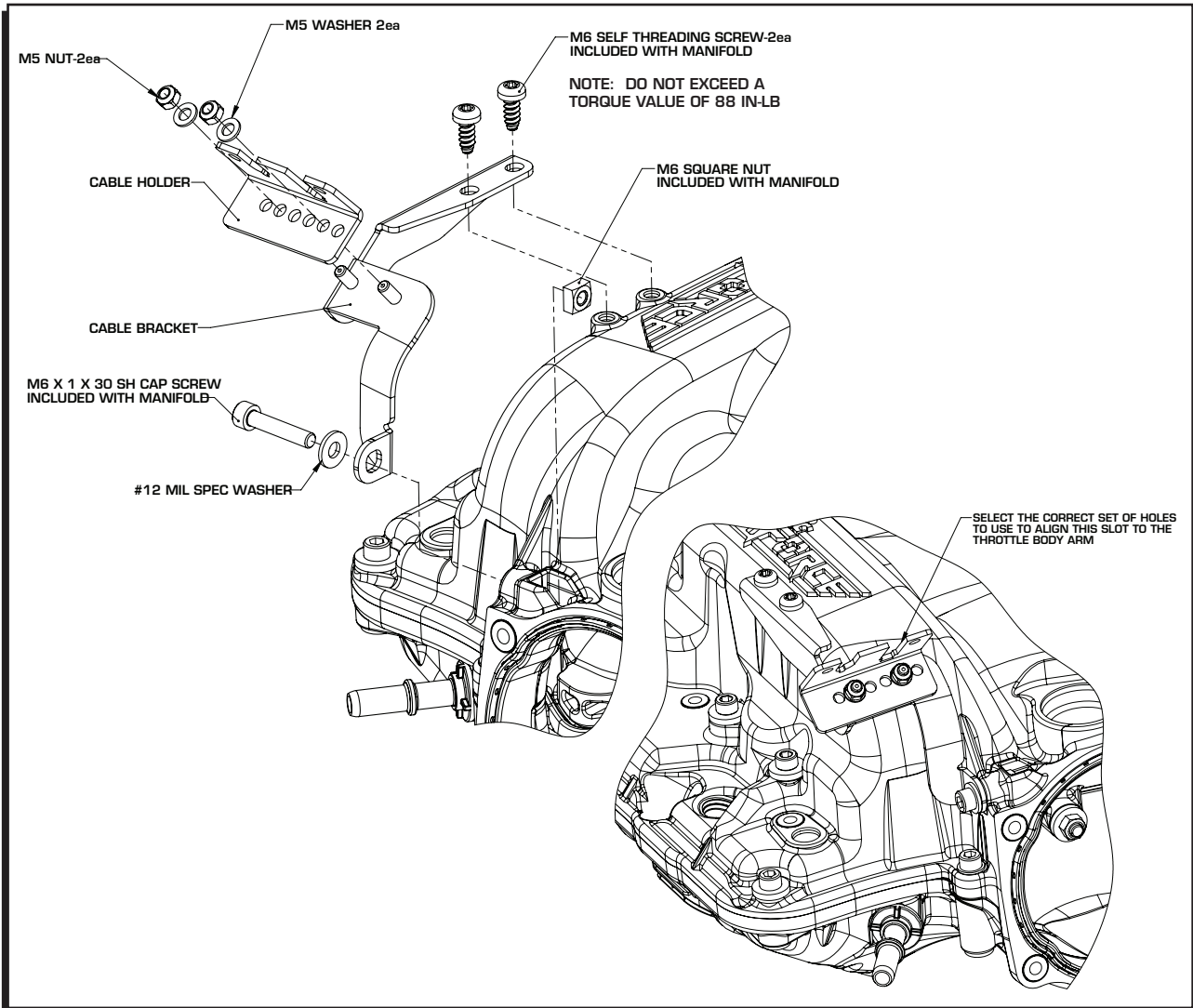

Figure 1 Throttle Cable Bracket Installation on LS1/2/3/6 AirForce Manifolds.

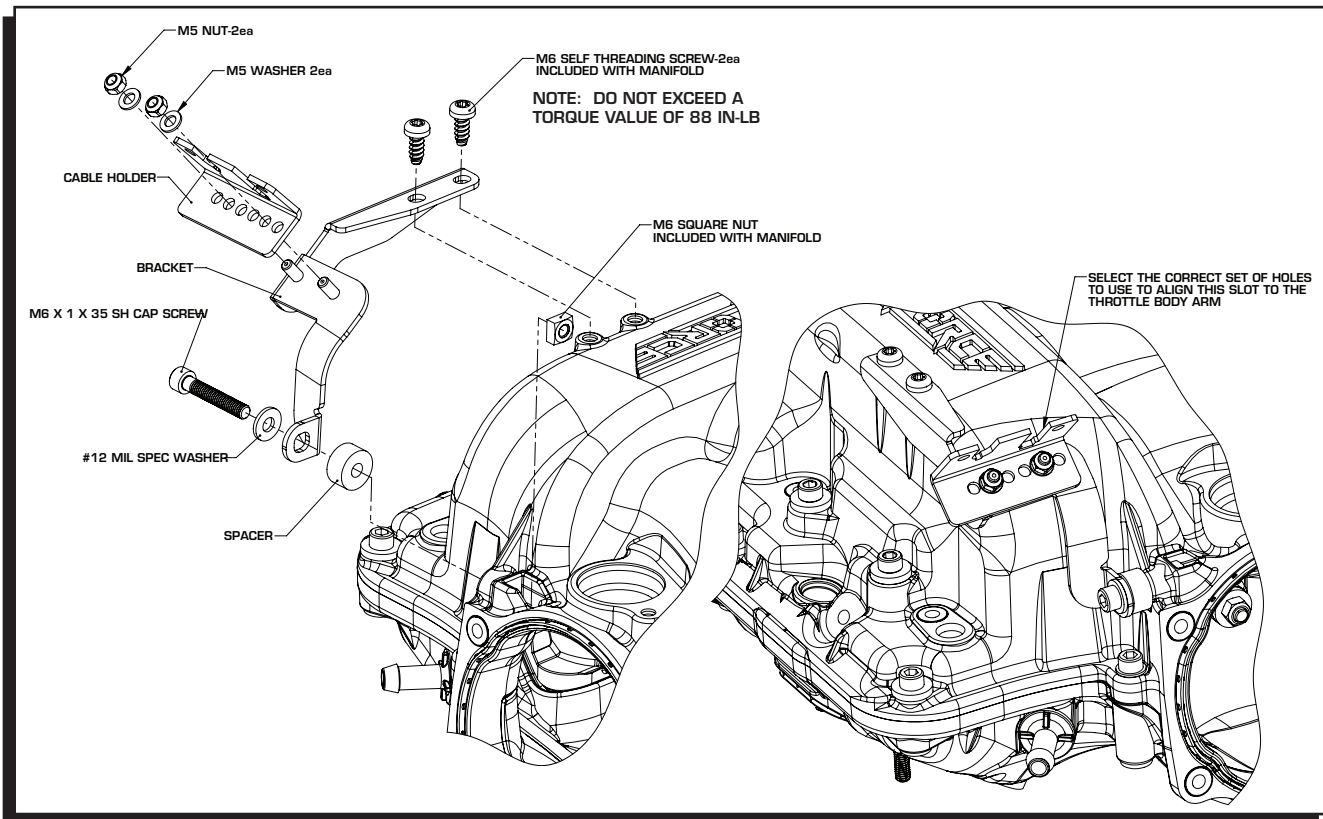

Figure 2 Throttle Cable Bracket Installation on LS7 AirForce Manifold.

Service

In case of malfunction, this MSD component will be repaired free of charge according to the terms of the warranty. When returning MSD components for warranty service, Proof of Purchase must be supplied for verification. After the warranty period has expired, repair service is based on a minimum and maximum fee.

All returns must have a Return Material Authorization (RMA) number issued to them before being returned. To obtain an RMA number please contact MSD Customer Service at 1 (888) MSD-7859 or visit our website at www.msdpower.com/rma to automatically obtain a number and shipping information.

When returning the unit for repair, leave all wires at the length in which you have them installed. Be sure to include a detailed account of any problems experienced, and what components and accessories are installed on the vehicle. The repaired unit will be returned as soon as possible using Ground shipping methods (ground shipping is covered by warranty). For more information, call MSD at (915) 855-7123. MSD technicians are available from 7:00 a.m. to 5:00 p.m. Monday - Friday (mountain time).

Limited Warranty

MSD warrants this product to be free from defects in material and workmanship under its intended normal use*, when properly installed and purchased from an authorized MSD dealer, for a period of one year from the date of the original purchase. This warranty is void for any products purchased through auction websites. If found to be defective as mentioned above, it will be repaired or replaced at the option of MSD. Any item that is covered under this warranty will be returned free of charge using Ground shipping methods.

This shall constitute the sole remedy of the purchaser and the sole liability of MSD. To the extent permitted by law, the foregoing is exclusive and in lieu of all other warranties or representation whether expressed or implied, including any implied warranty of merchantability or fitness. In no event shall MSD or its suppliers be liable for special or consequential damages.

*Intended normal use means that this item is being used as was originally intended and for the original application as sold by MSD. Any modifications to this item or if it is used on an application other than what MSD markets the product, the warranty will be void. It is the sole responsibility of the customer to determine that this item will work for the application they are intending. MSD will accept no liability for custom applications.