

#31000 ASSEMBLY ILLUSTRATION

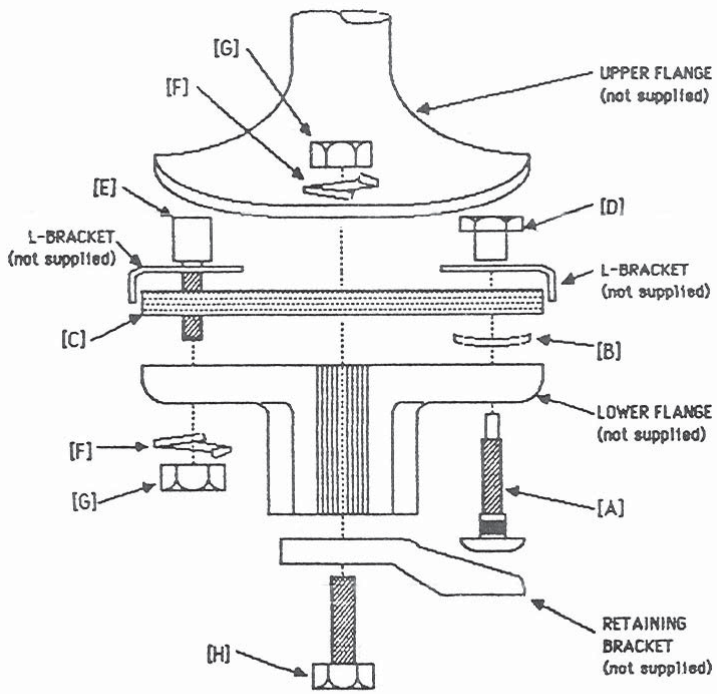

31000INSTR 08120

#31000 ASSEMBLY ILLUSTRATION

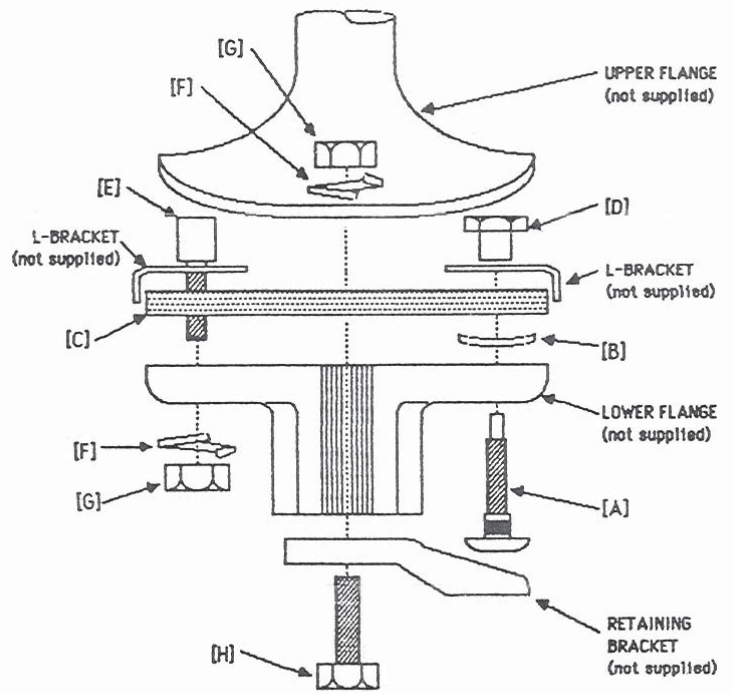

31000INSTR 08120

#31000 ASSEMBLY ILLUSTRATION

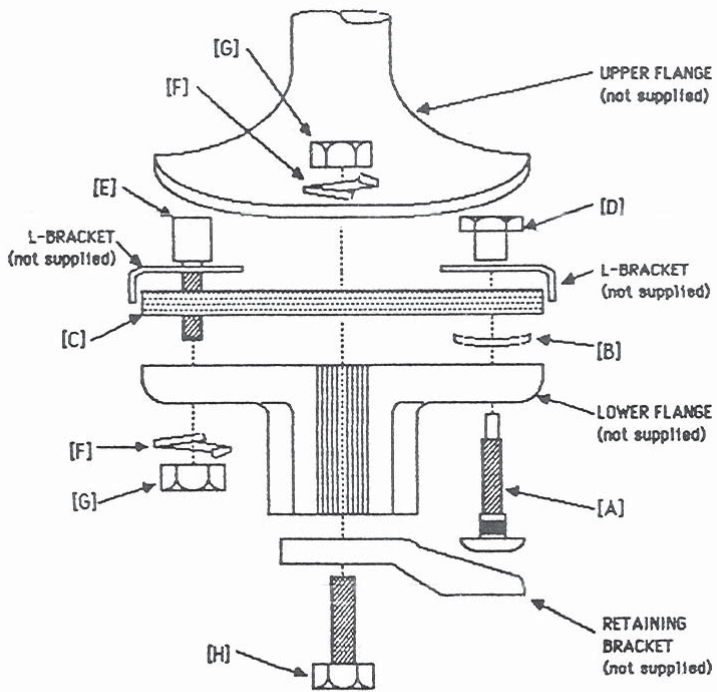

#31000 ASSEMBLY ILLUSTRATION

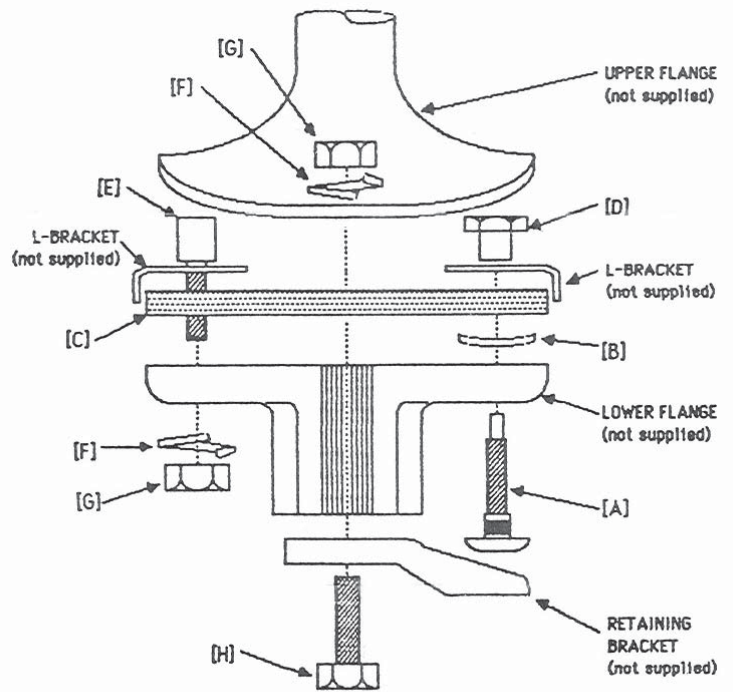

#31000 CONTENTS

- A. Pan Head Stud/Locating Pin (1)
- B. Spring Washer (1)
- C. Coupling Disk (1)
- D. Sleeve Nut (1)
- E. Large Head Stud/Locating Pin (1)
- F. Lock Washers (3)
- G. Hex Nuts (3)
- H. Cap Screws (2)

ASSEMBLY INSTRUCTIONS FOR MOST VEHICLES

1. Disassemble old joint. Remove nuts and bolts holding safety retaining bracket. If necessary, grind heads off locating pins to remove. Save retaining bracket and two L shaped brackets between pin and coupling disk for reassembly.
2. Position lower flange with slot facing up and mating surface away (see diagram) and insert pan head stud [A] through right hand side of flange. Assemble spring washer [B], coupling disk [C] and one L bracket onto threaded end of stud. Thread sleeve nut [D] onto stud so that sleeve fits into hole in coupling disk.
3. Pass threaded portion of large-head stud [E] through second L bracket, coupling disk and lower flange. Install lock washer [F] and hex nut [G] on flange side of assembly, and tighten both studs.
4. Reinstall joint assembly on splined shaft of steering box.
5. Orient upper flange (on lower end of steering column) so studs in joint are aligned in slots in flange, large-to-large and small-to-small.
6. Connect coupling and retaining bracket to upper flange using cap screws [H], lock washers and nut. Note that safety bracket is assembled so that it covers the head of stud [A].
7. Tighten all fasteners with appropriate wrench being careful not to over-tighten.

#31000 CONTENTS

- A. Pan Head Stud/Locating Pin (1)
- B. Spring Washer (1)
- C. Coupling Disk (1)
- D. Sleeve Nut (1)
- E. Large Head Stud/Locating Pin (1)
- F. Lock Washers (3)
- G. Hex Nuts (3)
- H. Cap Screws (2)

ASSEMBLY INSTRUCTIONS FOR MOST VEHICLES

1. Disassemble old joint. Remove nuts and bolts holding safety retaining bracket. If necessary, grind heads off locating pins to remove. Save retaining bracket and two L shaped brackets between pin and coupling disk for reassembly.
2. Position lower flange with slot facing up and mating surface away (see diagram) and insert pan head stud [A] through right hand side of flange. Assemble spring washer [B], coupling disk [C] and one L bracket onto threaded end of stud. Thread sleeve nut [D] onto stud so that sleeve fits into hole in coupling disk.
3. Pass threaded portion of large-head stud [E] through second L bracket, coupling disk and lower flange. Install lock washer [F] and hex nut [G] on flange side of assembly, and tighten both studs.
4. Reinstall joint assembly on splined shaft of steering box.
5. Orient upper flange (on lower end of steering column) so studs in joint are aligned in slots in flange, large-to-large and small-to-small.
6. Connect coupling and retaining bracket to upper flange using cap screws [H], lock washers and nut. Note that safety bracket is assembled so that it covers the head of stud [A].
7. Tighten all fasteners with appropriate wrench being careful not to over-tighten.

#31000 CONTENTS

- A. Pan Head Stud/Locating Pin (1)
- B. Spring Washer (1)
- C. Coupling Disk (1)
- D. Sleeve Nut (1)
- E. Large Head Stud/Locating Pin (1)
- F. Lock Washers (3)
- G. Hex Nuts (3)
- H. Cap Screws (2)

ASSEMBLY INSTRUCTIONS FOR MOST VEHICLES

1. Disassemble old joint. Remove nuts and bolts holding safety retaining bracket. If necessary, grind heads off locating pins to remove. Save retaining bracket and two L shaped brackets between pin and coupling disk for reassembly.
2. Position lower flange with slot facing up and mating surface away (see diagram) and insert pan head stud [A] through right hand side of flange. Assemble spring washer [B], coupling disk [C] and one L bracket onto threaded end of stud. Thread sleeve nut [D] onto stud so that sleeve fits into hole in coupling disk.
3. Pass threaded portion of large-head stud [E] through second L bracket, coupling disk and lower flange. Install lock washer [F] and hex nut [G] on flange side of assembly, and tighten both studs.
4. Reinstall joint assembly on splined shaft of steering box.
5. Orient upper flange (on lower end of steering column) so studs in joint are aligned in slots in flange, large-to-large and small-to-small.
6. Connect coupling and retaining bracket to upper flange using cap screws [H], lock washers and nut. Note that safety bracket is assembled so that it covers the head of stud [A].
7. Tighten all fasteners with appropriate wrench being careful not to over-tighten.

#31000 CONTENTS

- A. Pan Head Stud/Locating Pin (1)
- B. Spring Washer (1)
- C. Coupling Disk (1)
- D. Sleeve Nut (1)
- E. Large Head Stud/Locating Pin (1)
- F. Lock Washers (3)
- G. Hex Nuts (3)
- H. Cap Screws (2)

ASSEMBLY INSTRUCTIONS FOR MOST VEHICLES

1. Disassemble old joint. Remove nuts and bolts holding safety retaining bracket. If necessary, grind heads off locating pins to remove. Save retaining bracket and two L shaped brackets between pin and coupling disk for reassembly.
2. Position lower flange with slot facing up and mating surface away (see diagram) and insert pan head stud [A] through right hand side of flange. Assemble spring washer [B], coupling disk [C] and one L bracket onto threaded end of stud. Thread sleeve nut [D] onto stud so that sleeve fits into hole in coupling disk.
3. Pass threaded portion of large-head stud [E] through second L bracket, coupling disk and lower flange. Install lock washer [F] and hex nut [G] on flange side of assembly, and tighten both studs.
4. Reinstall joint assembly on splined shaft of steering box.
5. Orient upper flange (on lower end of steering column) so studs in joint are aligned in slots in flange, large-to-large and small-to-small.
6. Connect coupling and retaining bracket to upper flange using cap screws [H], lock washers and nut. Note that safety bracket is assembled so that it covers the head of stud [A].
7. Tighten all fasteners with appropriate wrench being careful not to over-tighten.