

The #1483 Ford Throttle Lever Kit will allow you to connect 1967 and newer Ford automatic transmission kick-down linkage to the Edelbrock Performer Series Carburetor (**Will not work with AOD**). If your vehicle has cable-type throttle linkage, you may also need the appropriate Edelbrock Throttle Cable Plate Kit. Please study these instructions carefully before installing your Ford Throttle Lever Adapter Kit. If you have any questions, do not hesitate to contact our **Technical Hotline at 1-800-416-8628**.

Installation of Adapter:

- Follow the PERFORMER SERIES CARBURETOR INSTALLATION INSTRUCTION sheet included with the carburetor. During step #1 of the "PREPARATION OF CARBURETOR FOR INSTALLATION" section you should attach the Throttle Lever Adapter to the existing throttle lever using the appropriate bolts, lockwashers, and nuts making sure the adapter is secured properly.
- Continue installing the carburetor according to the PERFORMER SERIES CARBURETOR INSTALLATION INSTRUCTIONS. While performing step #2 of the "INSTALLATION OF CARBURETOR," install the kick-down lever return spring bracket before tightening the nuts.
- Continue to install the carburetor using the PERFORMER SERIES CARBURETOR INSTALLATION INSTRUCTIONS.

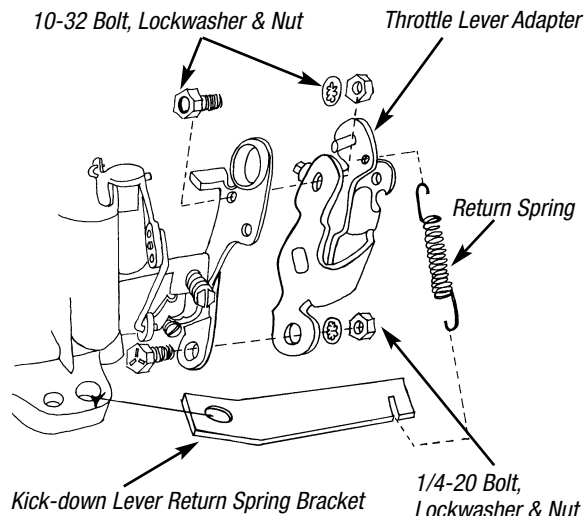

Kit Contents:

1—Throttle Lever Adapter	1—10-32 Bolt
1—10-32 Lockwasher	1—10-32 Nut
1—Kick-down Lever Return	1—1/4-20 Bolt
1—1/4-20 Lockwasher Spring Bracket	1—1/4-20 Nut