



Edelbrock E-Force Supercharger
2004-2007 Chevy Silverado and GMC Sierra
4.8L, 5.3L, 6.0L
Part # 1577, 15770



**Edelbrock Supercharger
2004-2007 GM Truck 4.8L, 5.3, 6.0L**

Installation Instructions

E-MAIL EDELBROCK YOUR STOCK VEHICLE CALIBRATION AND VEHICLE INFORMATION

PLEASE COMPLETE THIS PROCEDURE PRIOR to starting the installation of your E-Force supercharger system. This will allow our calibration team to complete your calibration file while the installation of your supercharger system is being completed. Manufacturers regularly update the factory calibration, as a result, there is the possibility for delays due to not having access to your current calibration file. This can normally be resolved in 1 business day.

FAILURE TO PROVIDE ALL OF THE INFORMATION BELOW WILL DELAY THE COMPLETION OF THE CALIBRATION FILE FOR YOUR VEHICLE. TO LIMIT VEHICLE DOWN TIME, PLEASE SEND US THE REQUESTED INFORMATION BEFORE STARTING THE SUPERCHARGER INSTALL.

Please e-mail the requested information below to calibration@edelbrock.com with the E-mail Subject as **“Calibration Update”**. We will complete your calibration and e-mail it back to you as soon as possible. MOST calibration updates will be sent back the same business day. In rare cases, it could take up to 1-2 business days to complete. Please contact our Tech Hot Line at (800)416-8628 if you have any questions or if you need assistance with this procedure.

- Begin by downloading the SCT device updater software to your computer; it can be downloaded from: <http://www.sctflash.com/software/SCTDeviceUpdater.exe>
- Put the vehicle into ACC mode but do not start the engine.
- Connect the supplied PCM cable from the programmer to the OBD-II connector.
- Select PROGRAM VEHICLE, use the arrow keys to highlight UPLOAD STOCK and press SELECT. Follow the prompts on the screen.
- If the upload fails, you will be asked to AUTO DETECT. Press SELECT and follow the prompts on the screen. If the auto detect fails, please contact Edelbrock Tech Support @ 800-416-8628.
- Once the stock calibration has loaded to the handheld programmer, disconnect the programmer from the OBD-II connector and connect it to your PC using the supplied USB cable.
- Open the SCT software and select the button on the lower left hand side that reads GET STOCK FILE FROM DEVICE. Follow the instructions on the screen. **NOTE: The stock calibration file will automatically be labeled using your VIN number followed by “.sul “ (XXXXXXXXXXXX.sul)**
- Once the download is complete, you can E-mail your stock vehicle calibration along with the vehicle information below to calibration@edelbrock.com or call 800-416-8628 and our Tech Support staff will assist you with E-mailing the file. **NOTE: The subject line of your E-mail should read “Calibration Update”.**
- Once we have the stock calibration file, along with the requested information below, we can update the calibration to work with your application. We will E-mail you the custom calibration which may be used until the release version of the calibration is available.

INFORMATION NEEDED:

E-Mail Address:

Vehicle Year:

Vehicle Make:

Vehicle Model (Specify if Z06, Z51, etc.):

Engine Size:

Transmission:

Fuel Octane (91 or 93 ONLY):

Supercharger System Part Number:

Supercharger Serial Number:

Programmer Serial Number:



Edelbrock Supercharger 2004-2007 GM Truck 4.8L, 5.3, 6.0L

Installation Instructions

INTRODUCTION

Thank you for purchasing the Edelbrock E-Force Supercharger System for 2004 to 2007 Chevy Silverado and GMC Sierra. This supercharger utilizes Eaton's new Gen VI TVS rotors, featuring a four lobe design with a full 160°. of twist for maximum flow, minimum temperature rise, quiet operation, and the reliability for which Eaton is known. The Edelbrock Supercharger is a complete system that maximizes efficiency and performance by minimizing air restriction into, and out of, the supercharger. This results in maximum airflow, with minimal temperature rise and power consumption. The supercharger housing itself is integrated into the intake manifold for a seamless design with minimal components, eliminating the possibility of vacuum leaks between gasket surfaces. The system also utilizes a front drive, front inlet configuration giving it the shortest, least restrictive inlet path on the market. The supercharger is inverted, expelling the air upward. Air pressure then builds in the plenum, before being drawn down through each of two intercooler cores, oriented horizontally, next to, and below the supercharger outlet. After passing through the intercooler cores, the air travels through the long 12" runners, which route underneath the supercharger housing to the cylinder head ports, in a horizontal, nested configuration. The upper plenum area is enclosed by a top cover that has been designed to provide an appealing and distinctive under-hood appearance. This configuration allows for a compact package that can fit under the stock hood and cowl of the vehicle, without sacrificing runner length, or intercooler area. The E-Force supercharger features a uniquely styled plenum. The Edelbrock supercharger provides neck snapping performance that is safe to operate on a completely stock engine. It is 50-state emissions legal.

TOOLS AND SUPPLIES REQUIRED

- Jack and Jack Stands
OR Service Lift
- Panel Puller
- Ratchet and Socket Set including: 1/4", 7mm, 8mm, 10mm (standard, deep and universal), 11mm, 12mm (deep), 13mm, 14mm, 15mm, 18mm, 21mm (deep), 24mm
- Wrenches including: 8mm, 10mm, 14mm, 15mm, 27mm
- 12" Ratchet Extension Bar
- 1/2" Breaker Bar
- Flat Blade & Phillips Screwdrivers
- Compressed Air
- Torx - T20, T25, T30 Driver
- Allen Wrenches including: 5mm, 6mm, 8mm
- 2" Long 5mm Allen Socket
- 3/8" Fuel Line Removal Tool
- Torque Wrench
- GM J46406 or equivalent (fan clutch tool)
- Metal Punch
- Needle Nose Pliers
- Bench Vice OR C-Clamp
- Hose Clamp Removal Tool
- Grinding Tool (Dremel) or equivalent
- Pneumatic OR Right Angle Power Drill
- Hole Saw: 1-1/8"
- Punch
- Impact Wrench
- Red Loctite or equivalent
- Permatex Thread Sealant w/ PTFE, or equivalent
- O-ring Lube
- Anti-seize
- Masking Tape
- Shop Rags
- Zip Ties / Wire Ties
- J-42386-A Flywheel Holding Tool
- 50/50 Coolant Mixture



**Edelbrock Supercharger
2004-2007 GM Truck 4.8L, 5.3, 6.0L**

Installation Instructions

IMPORTANT WARNINGS

Before beginning installation, use the enclosed checklist to verify that all components are present in the box then inspect each component for damage that may have occurred in transit. If any parts are missing or damaged, contact Edelbrock Technical Support (1-800-416-8628), not your parts distributor.



WARNING: *Installation of this supercharger will result in a significant change to the performance characteristics of your vehicle. It is highly recommended that you take some time to familiarize yourself with the added power, and how it is delivered, in a controlled environment. Take extra care on wet and slippery roads, as the rear tires will be more likely to lose traction, with the added power. It is never recommended to turn off your vehicles traction control system.*

Please employ proper towing etiquette when towing steep grades. Turn off Air Conditioner and avoid aggressive towing behaviors to avoid any overheating that may occur. DO NOT exceed the manufacturer's maximum tow rating for the vehicle.

Proper installation is the responsibility of the installer. Improper installation will void all manufacture's standard warranties and may result in poor performance and engine or vehicle damage.

Due to the complexity of the Edelbrock E-Force Supercharging system, it is recommended that this system only be installed by a qualified professional with access to a service lift, pneumatic tools, and a strong familiarity with automotive service procedures. **To qualify for the optional supplemental warranty**, it is necessary to have this system installed by a Certified ASE Technician at a licensed business, GM Dealership, or an Authorized Edelbrock Installer. Failure to do so will void and/or disqualify any and all optional supplemental warranties offered with this system. Please contact the Edelbrock Technical Support department if you have any questions regarding this system and/or how your installer of choice will affect any warranty coverage for which your vehicle may qualify.

Any previously installed aftermarket tuning equipment must be removed and the vehicle returned to an as stock condition before installing the supercharger.

Any equipment that directly modifies the fuel mixture or ignition timing of the engine can cause severe engine damage if used in conjunction with the Edelbrock E-Force Supercharger System. This includes, but is not limited to: ignition boxes, air/fuel controllers, OBD-II programmers, and any other device that modifies signals to and/or from the ECU. Using the supercharger in conjunction with other aftermarket equipment such as headers, air intakes, etc. will require custom tuning.



**Edelbrock Supercharger
2004-2007 GM Truck 4.8L, 5.3, 6.0L**

Installation Instructions

IMPORTANT WARNINGS (CONTINUE)

It is also recommended that you check the Edelbrock Tech Center Website for any updates to this installation manual. Please refer to the lower left hand corner to verify that you have the latest revision of this installation manual before beginning the installation.

Tech Center: http://www.edelbrock.com/automotive_new/misc/tech_center/install/index.php



91 octane or higher gasoline is required at all times. If your vehicle has been filled with anything less, it must be run until almost dry and refilled with 91 or higher octane gasoline twice prior to installation.

NOTE: If a supplemental fuel pump kit is required for installation, the tank can be drained once removed from the vehicle.

Any failures associated with not using premium 91 octane gasoline or higher, will be ineligible for warranty repairs.

THE FLEX-FUEL FUNCTION HAS BEEN DISABLED. DO NOT USE ANY GASOLINE WITH AN ETHANOL RATING HIGHER THEN 10% (E10). FAILURE TO DO SO WILL RESULT IN ENGINE DAMAGE AND VOID YOUR WARRANTY

Edelbrock Authorized Installer Disclaimer

Authorized installers of Edelbrock products are independent companies over which Edelbrock has no right of control. Edelbrock LLC makes no claims regarding the abilities, expertise or competency of individual employees of any authorized installer. Each authorized installer is an independent company and makes its own independent judgments. Edelbrock LLC specifically disclaims any responsibility to any party including third parties for the actions, or the failure to act, of individuals, agents or a company authorized in the installation of Edelbrock LLC products.



**Edelbrock Supercharger
2004-2007 GM Truck 4.8L, 5.3, 6.0L**

Installation Instructions



SUPPLEMENTAL FUEL PUMP KIT REQUIRED

All vehicles will require an Edelbrock's Supplemental Fuel Pump Kit (details below). Please visit our website or call our Tech line at 1-800-416-8628 for more information.

DESCRIPTION: These supplemental fuel pump kits (*sold separately*) include a replacement fuel pump, fuel level sending unit, and other fuel components (*see below*). These upgrade kits are required for all GM Trucks utilizing the #1577 E-Force supercharger system (*see kit and model breakdown below*). **Failure to use the supplemental fuel pump kit may result in engine damage and void your Edelbrock E-Force Supercharger's warranty.**

Fuel Pump Kit for vehicles with a Return Style Fuel Systems:

#15773 Kit includes the following:

- 1 - Fuel Pump
- 1 - Fuel Level Sending Unit
- 1 - Adapter, Fuel Pressure Regulator
- 1 - Bracket, EVAP and Fuel Pressure Regulator
- 1 - Fuel Hose, Regulator to Rail
- 1 - Fuel Hose, Output to Regulator
- 1 - Fuel Hose, Regulator to Return
- 1 - Vacuum Hose, 3/16" (1 Feet)
- 1 - Tee Reducer
- 1 - Retaining Ring
- 2 - Hex Flange Bolt, M6 x 1.0 x 16mm
- 2 - Hex Nut, M6 x 1.0
- 2 - Washer, Flat M6

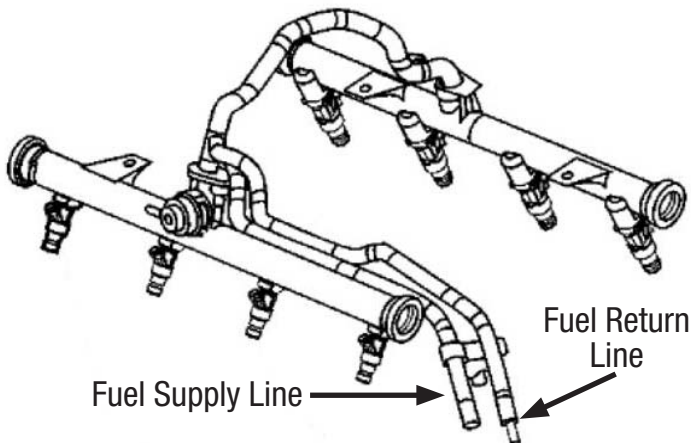

Fuel Pump for vehicles with a Returnless Fuel Systems:

#15775 Kit includes the following:

- 1 - Fuel Pump
- 1 - Fuel Level Sending Unit
- 1 - 3/8" Quick-Disconnect Fitting, Male to Female
- 1 - Plug, 1/8" NPT (for the fitting)

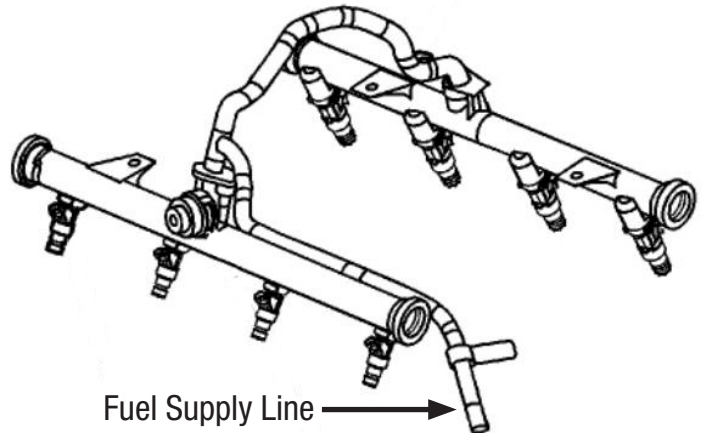



**Edelbrock Supercharger
2004-2007 GM Truck 4.8L, 5.3, 6.0L**

Installation Instructions

INSTALLATION HARDWARE IDENTIFICATION GUIDE

Bag #1



(2x) - M10 x 1.50 x 90mm
Hex Flange Bolt



(4x) - M6 x 1 x 40mm
Hex Flange Bolt



(1x) - M8 x 1.25 x 20mm
Hex Flange Bolt



(1x) - Rubber Grommet



(1x) - M8 Washer

Bag #2



(6x) - M6 x 1 x 16mm
Hex Flange Bolt



(2x) - 1/2"
Hose Clamp



(8x) - 3/4"
Hose Clamp



(1x) - M8 x 1.25 x 30mm
Hex Flange Bolt



(2x) - Washer
5/16 ID



(2x) - M6 x 1 x 35mm
Hex Flange Bolt



(2x) - M6 x 1 x 25mm
Hex Flange Bolt



(5x) - M6 x 1 x 10mm
Hex Flange Bolt



(8x) - Nut
M6 x 1.0



(2x) - 1" Spacer

Bag #3



(10x) - M8 x 1.25 x 30mm
Button Head Bolt



(11x) - M8 x 1.25 x 25mm
Countersunk Socket Head Bolt



(8x) - M6 x 1 x 45mm
Hex Flange Bolt



(4x) - M6 x 1 x 12mm
Socket Head Bolt



(2x) - M6 x 1 x 16mm
Button Head Bolt



**Edelbrock Supercharger
2004-2007 GM Truck 4.8L, 5.3, 6.0L**

Installation Instructions

Bag #4

(1x) - GM Factory Harmonic Balancer Bolt



(1x) - M16 x 2 x 120mm Hex Bolt



(1x) - Crank Pinning Drill Guide

(1x) - 15/64" High Speed Steel Drill Bit



(1x) - 1/4" x 3/4"
Steel Dowel



(1x) - .2500" Reamer



Bag #5



(1x) - Vacuum Cap



(3x) - M6 x 1.0 x 35mm
Hex Flange



(1x) - 8mm Straight
Quick Connect



(1x) - 10mm Straight
Quick Connect



HOSE IDENTIFICATION GUIDE

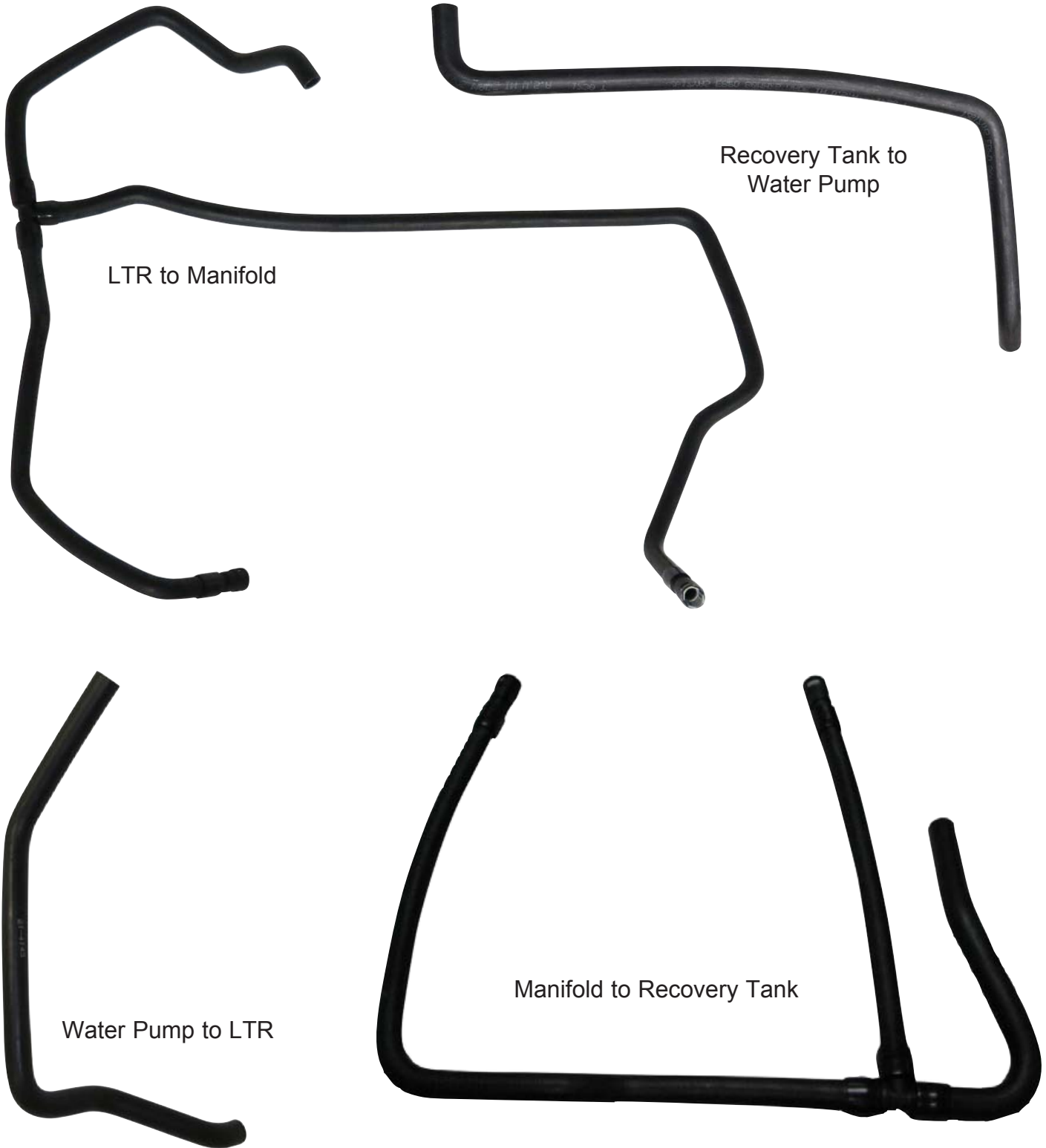



HOSE IDENTIFICATION GUIDE CONTINUED

Driver side PCV
Valve Cover to Manifold Nose



Passenger Side PCV
Valve Cover to Throttle Body Flange



Rear EVAP Hose

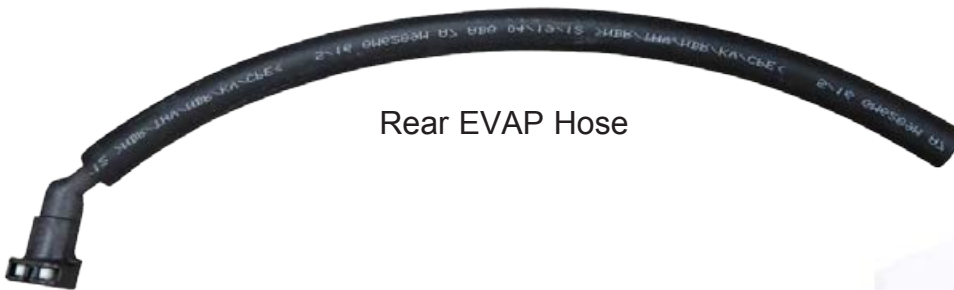

Front EVAP Hose



Coolant Crossover
Hose



Brake Booster Hose





**Edelbrock Supercharger
2004-2007 GM Truck 4.8L, 5.3, 6.0L**

Installation Instructions

WIRE HARNESS GUIDE

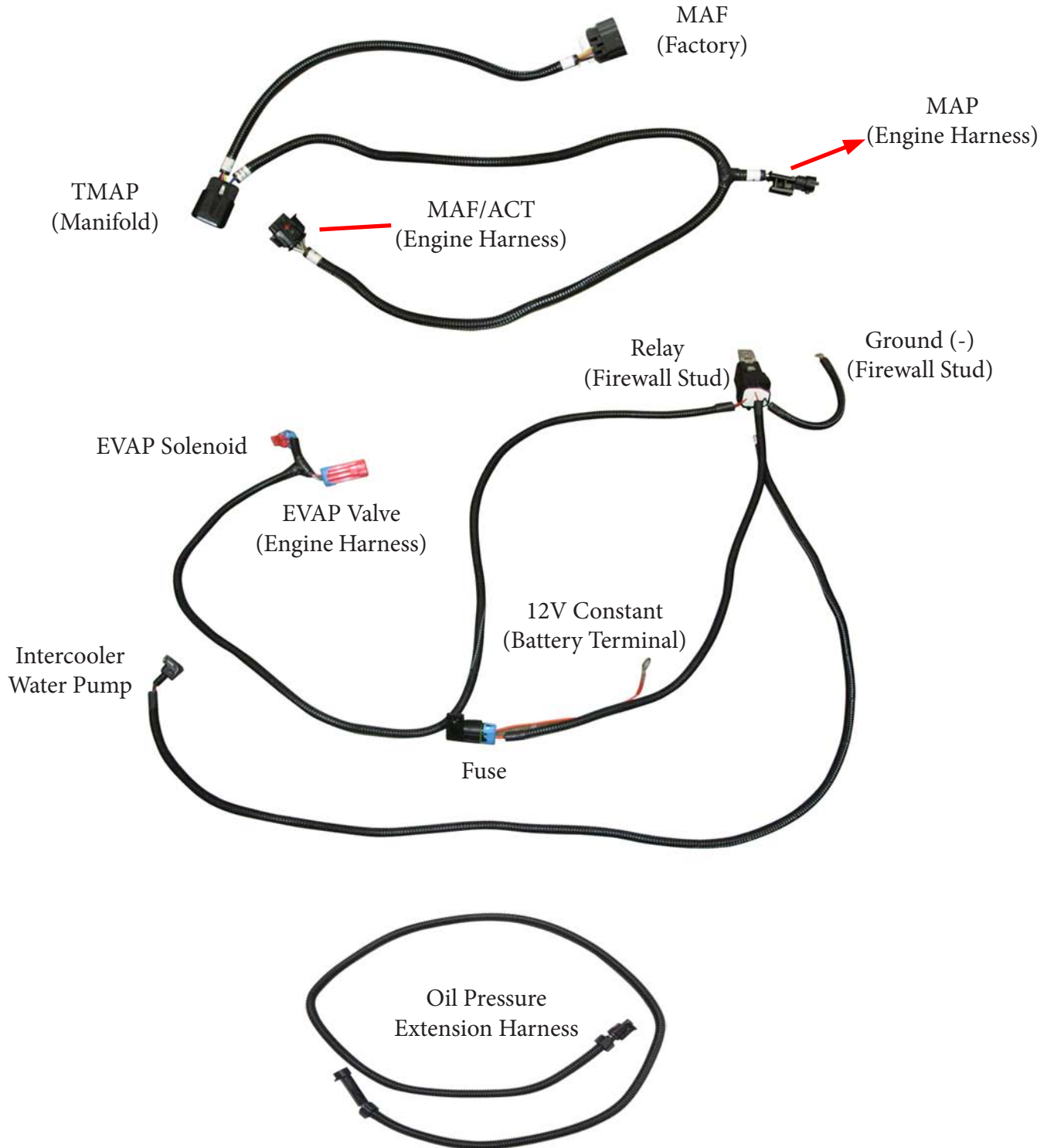



**Edelbrock Supercharger
2004-2007 GM Truck 4.8L, 5.3, 6.0L**

Installation Instructions

HOSE ROUTING GUIDE

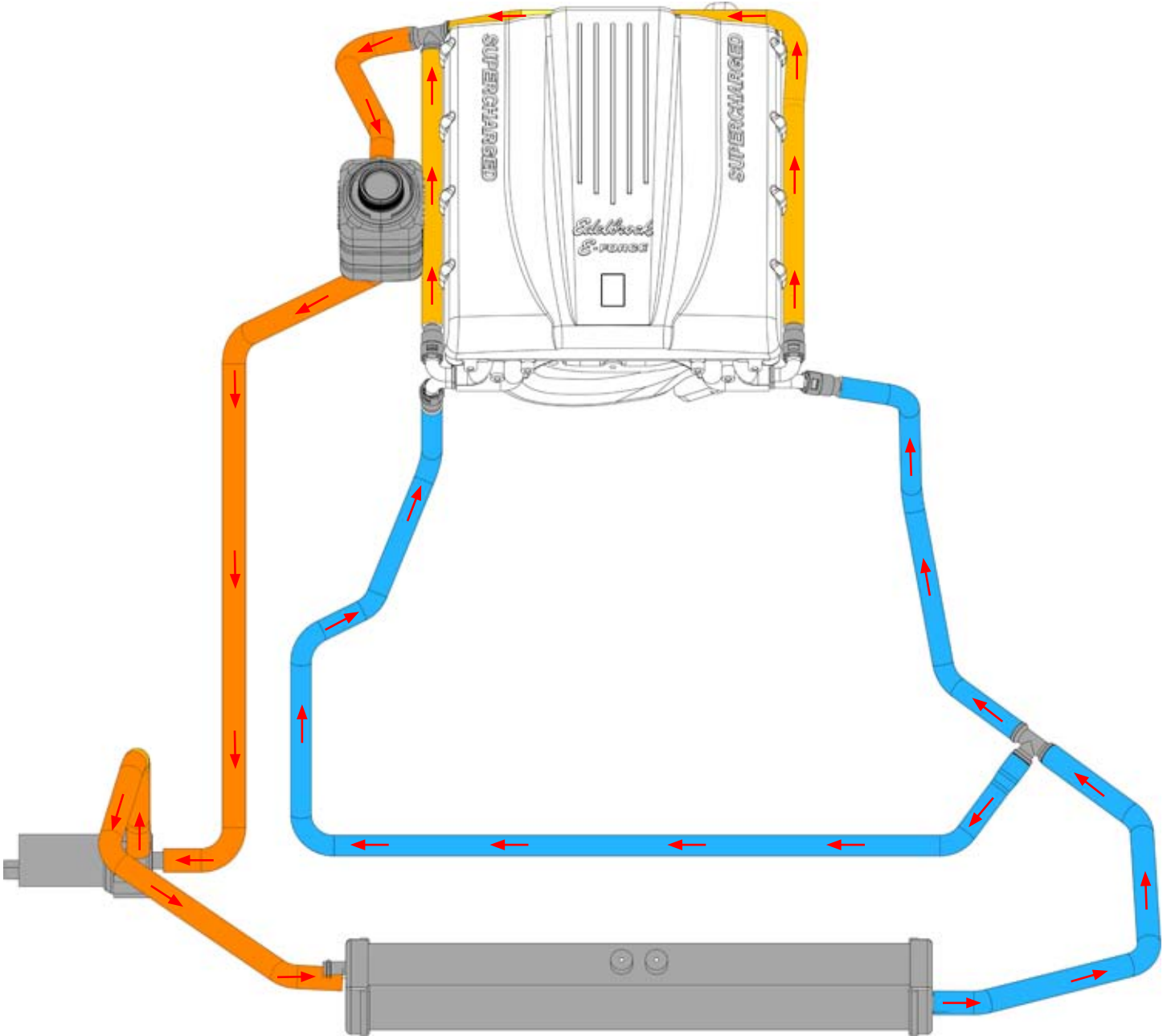



Edelbrock Supercharger 2004-2007 GM Truck 4.8L, 5.3, 6.0L

Installation Instructions

Supercharger Installation

WARNING: Battery must be sufficiently charged before starting the PCM flashing procedure.

Only begin the PCM flashing procedure when you have downloaded the calibration file from the Edelbrock Calibration Team to the handheld programmer. Do not flash the PCM until you are ready to install the supercharger. Once the PCM is flashed, DO NOT START the engine until the installation of the E-Force supercharger is complete.

1. Put the car into ACC mode, but don't start the vehicle.
2. Connect the supplied PCM cable on the handheld programmer to the OBD-II connector located below the steering wheel, and to the left of your knee.
3. Use the directional pad to highlight the Program Vehicle option and press the Select button.

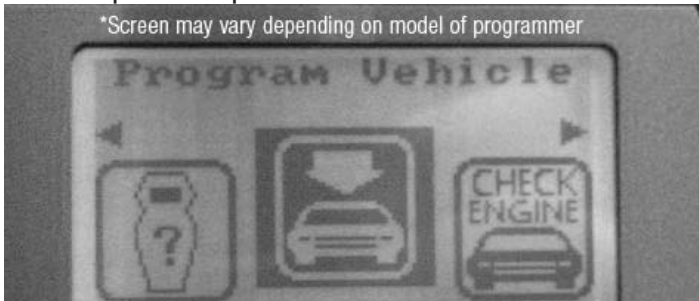

4. Use the directional pad to highlight the Pre-programmed Tune option and press the Select button.
5. Read the disclaimer then press Select to continue.
6. Verify that the ignition is in the 'Key On' position and that the engine is not running, then press Select.
7. Use the directional pad to highlight your vehicle and transmission combination then press Select.
8. Use the directional pad to highlight the Begin Program option then press Select.
9. Depending on your specific drivetrain configuration, several separate operations may take place during this step. Completion of each operation will cause the progress bar to reset to zero.

10. DO NOT unplug the programmer until prompted.

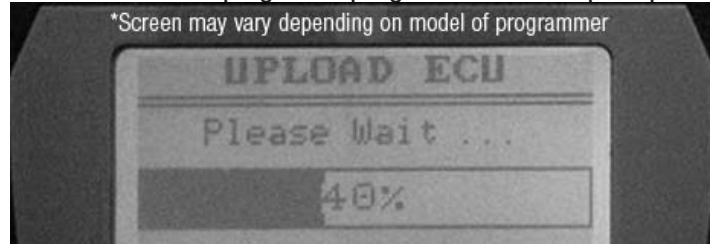

11. Turn the vehicle off when prompted to do so by the handheld programmer.
12. Read the parting message from programmer then press Select to continue.
13. Unplug the programmer cable from the OBD-II port. This concludes the PCM flashing procedure. DO NOT start the engine until the supercharger installation is complete.
14. Using a 8mm wrench, remove the negative battery terminal.
15. Remove four (4) bolts securing the skid plate using a 15mm socket (if equipped). Drain the coolant (as needed) by removing the petcock from the radiator (or by removing lower radiator hose). Reinstall the petcock or lower radiator hose once coolant is drained.
16. Using a flat blade screwdriver, remove the radiator shroud by prying up the heads of the six (7) push-pins, then use a panel puller to fully remove the push pins. Lift the radiator shroud off the vehicle and set aside.





Edelbrock Supercharger 2004-2007 GM Truck 4.8L, 5.3, 6.0L

Installation Instructions

17. Carefully disengage two (2) upper and two (2) lower retaining clips located behind the grill.



18. Disengage one (1) retaining clip on the passenger side of the grill and one (1) from the driver side of the grill. Remove grill and set aside.



19. Using a flathead screwdriver, remove the intake tube by loosening the two (2) worm clamps securing the intake tube.



20. Using an 8mm socket, remove the bolt securing the engine cover. Remove engine cover and set aside.



21. Using a 10mm socket, remove the three (3) bolts securing the engine cover support brace. Remove brace and set aside.



22. Unravel the retainer bracket from the engine harness to remove the retainer bracket from the harness assembly.



23. Unplug the EVAP solenoid connector located on the upper front of the manifold.



24. Disconnect the EVAP hose located on the upper front of the manifold and the rear of the engine by pushing in the white release tab and pulling the EVAP hose up.





Edelbrock Supercharger 2004-2007 GM Truck 4.8L, 5.3, 6.0L

Installation Instructions

25. Remove the driver side PCV hose from the top of the manifold and the rear of the driver side valve cover.



29. Remove the passenger side PCV from the passenger side valve cover.



26. Remove the brake booster hose from the check valve located on the brake booster. Disregard if vehicle does not have a brake booster hose.



30. Remove the plastic cap on the schrader valve located on the passenger side fuel rail. Place a towel over the schrader valve and carefully release the pressure from the fuel system using a small flat head screwdriver or equivalent. Remove the fuel hose safety clip, then remove the fuel supply line using a 3/8" Fuel Line Removal Tool.

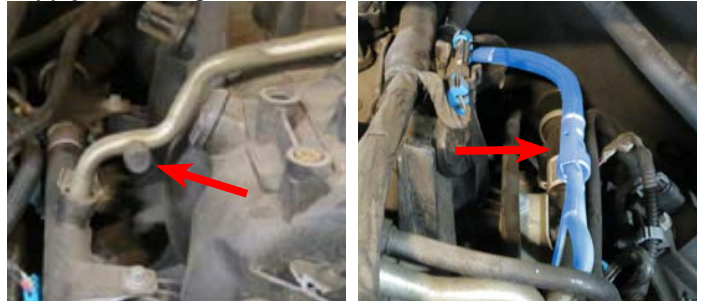

27. Disconnect the throttle position sensor located on the side of the throttle body. Remove coolant hoses from the throttle body.



31. Disconnect all eight (8) injector plugs (four on the driver side and four on the passenger side).

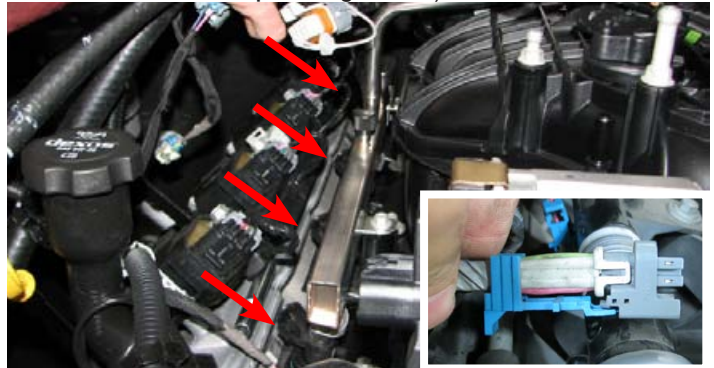

28. Disconnect the MAP sensor located on the upper rear of the manifold.





Edelbrock Supercharger 2004-2007 GM Truck 4.8L, 5.3, 6.0L

Installation Instructions

32. Using a GM J46406 or equivalent, remove the fan clutch assembly and set aside.



33. Using a 15mm socket and a breaker bar, remove the serpentine belt by rotating the tensioner clockwise until the belt can slide off the idler pulley.

34. Unplug the alternator connector and remove the power cable using a 10mm socket. Now remove the two (2) bolts, using a 15mm socket to fully remove the alternator.



35. Remove the idler pulley on the alternator bracket using a 15mm socket.

NOTE: Hardware from this idler pulley (bolt, washer and bushing) will be reused later.



36. Unhook the main engine harness from the rubber hooks on the intake manifold and move the harness behind the manifold.

37. Remove ten (10) bolts securing the manifold using an 8mm socket. Carefully lift up the manifold assembly and remove.

38. Use a clean shop rag to wipe down the intake flange of both cylinder heads. Apply masking tape to the head ports to prevent any dirt or debris from entering the ports.



39. Using a 10mm socket, remove the bracket securing the heater hoses and set aside.



40. Unplug the coil pack main harnesses and the coil boots. Remove the driver & passenger side coil bracket assemblies by removing five (5) bolts (on each side) using a deep 10mm socket.

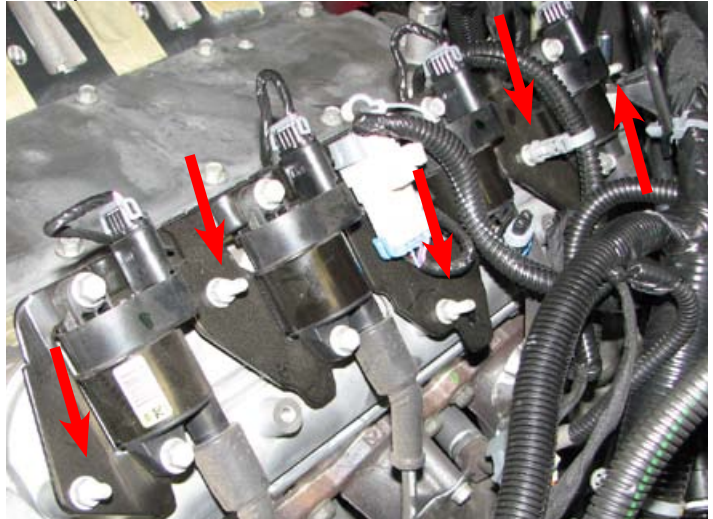



Edelbrock Supercharger 2004-2007 GM Truck 4.8L, 5.3, 6.0L

Installation Instructions

41. Remove the rear engine support brace attached to the rear of the driver side cylinder head using a 15mm socket.



NOTE: The oil pressure sensor has to be relocated as it will interfere with the supercharger manifold.

42. Unplug the oil pressure sensor. Use a 27mm wrench to remove the oil pressure sensor located behind the valley tray.



NOTE: Check the oil pressure sensor to verify that the connector insulator is not stuck inside the sensor. Make sure to remove the insulator before proceeding.

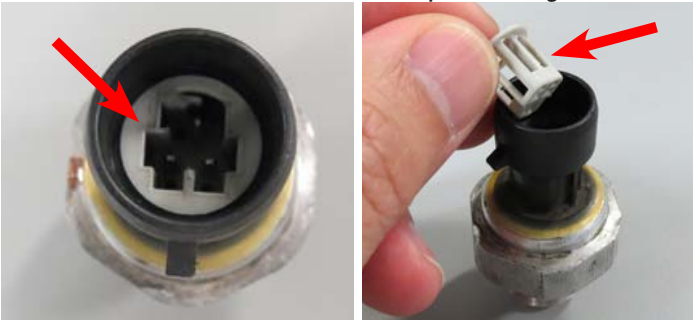

43. Using a 8mm Allen wrench, remove the factory plug towards the front driver side of the block, adjacent to the crank pulley. Apply thread sealant w/ PTFE to the threads of the factory oil pressure sensor and install the sensor in the location of the plug. Torque to 26 ft/lbs (35 Nm).

NOTE: DO NOT use Teflon tape as it will not seal properly.



44. Apply thread sealant w/ PTFE to the threads on the plug removed from the engine block and install it to the factory oil sensor location.

NOTE: DO NOT use Teflon tape as it will not seal properly.

45. Connect the supplied oil pressure sensor extension harness to the factory oil pressure harness. Route the extension harness over the driver side valve cover towards the front of the vehicle. Then straight down and connect it to the oil pressure sensor. Keep the harness away from the exhaust manifold and secure it with wire ties to nearby vehicle harnesses.

NOTE: The factory valley tray bolts have to be replaced as it will interfere with the supercharger manifold.

46. Using a 13mm socket, remove ten (10) valley tray bolts and replace with ten (10) button head bolts supplied in Bag #3 using a 5mm Hex tool. Tighten in a criss cross pattern starting from the inside and working outwards. Torque bolts to 18 ft/lbs (25 Nm).

47. Raise the front of the vehicle using a service lift or equivalent.



Edelbrock Supercharger 2004-2007 GM Truck 4.8L, 5.3, 6.0L

Installation Instructions

48. Unbolt the starter by removing two (2) bolts with a 13mm socket. Now remove the flywheel cover using a 10mm socket. Move the starter aside as it is difficult and unnecessary to remove completely.

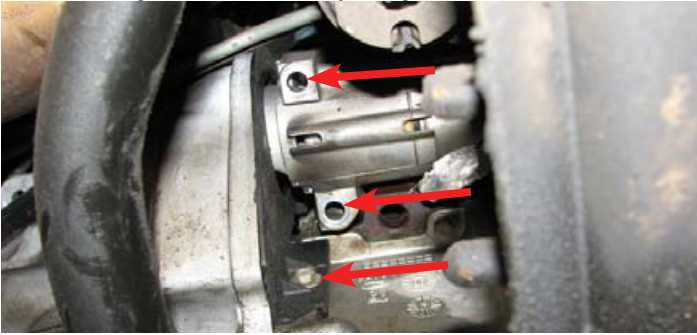

49. Install GM Flywheel Holding Tool #J-42386-A or equivalent, to prevent the crank from rotating while loosening the balancer bolt. Torque the bolts to 37 ft/lbs (51 Nm).

50. Remove the balancer bolt, using a breaker bar and a 24mm socket.

TIP: A long pipe slid over the breaker bar can be helpful for increasing leverage.

51. Loosely install the supplied hex bolt and drilling guide to the end of the crank. Rotate the drilling guide until the drilling bushing is at a comfortable position for drilling. Securely tighten the drilling guide and bolt using a 24mm socket.



52. Mark the supplied drill bit with a piece of masking tape. It must measure 1.6" from the tip.

53. Lubricate the drill bit with a small amount of engine oil. Then locate the guide hole with the drilling bushing. Begin drilling using a Right Angle Drill (or equivalent) and the supplied 15/64" drill bit. The drilling process is complete when the tape mark on the bit meets the guide.

54. Loosen the balancer bolt and remove any metal debris with compressed air. Rotate the guide until the ream hole lines up with new dowel pin hole on the crank. Use the supplied .2500" ream tool to verify that the holes are aligned. Then tighten the bolt and ream the hole.

55. Remove the balancer bolt and drilling guide. Clear out any remaining metal debris with compressed air. Apply Loctite 609 Retaining Compound, or equivalent, to the supplied dowel pin and gently tap it into the new dowel pin hole until it is flush.

56. Install the supplied balancer bolt onto the crank. Torque it to 37 ft-lbs (51 Nm), then rotate it an additional 140°.

57. Remove the GM Flywheel Holding Tool and reinstall the flywheel cover and starter using the factory bolts. Torque starter bolts to 37 ft-lbs (51 Nm).

58. Two (2) of the stock intake manifold bolt holes in the cylinder heads break into the crankcase and are not used with this supercharger. Remove the tape covering the intake ports. **Apply Loctite 567 or equivalent thread sealant to the threads of the two (2) button head bolts supplied in Bag #3 and install them in the front passenger side and rear driver side intake manifold bolt holes.**

59. Remove the hose on the coolant crossover. Install the supplied 1/4" hose onto the coolant crossover barb and secure with the factory hose clamp. Secure the hose away from the intake ports. **NOTE: The hose clamp will be difficult to access if this is done after the supercharger has been installed.**

60. Using the appropriate quick connect fittings from Bag #5, install the rear EVAP hose onto the EVAP barb on the rear of the engine. Move the other end of the EVAP hose aside as it will be installed to the EVAP later.





Edelbrock Supercharger 2004-2007 GM Truck 4.8L, 5.3, 6.0L

Installation Instructions

61. Remove the gaskets on the factory intake manifold if not already done so. Using side cutters or equivalent, trim down the three (3) retention clips and the center locating tab. Use CAUTION while trimming the clips. Re-inspect the gaskets after modification for any tears and replace as necessary. Install onto the manifold to verify a flush fit.

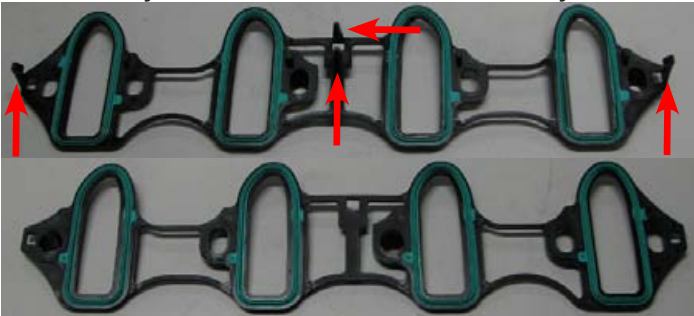

62. Install the modified intake manifold gaskets onto the supercharger manifold using the installed bushings as guides.

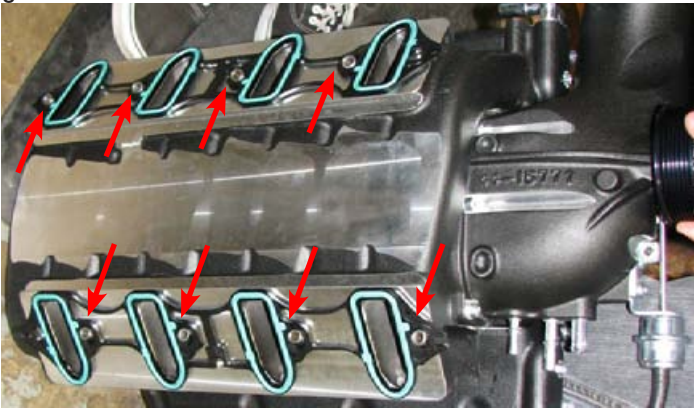

63. Connect the supplied TMAP harness to the MAP sensor on the back of the supercharger. Bundle the harness up and wrap over the top of the manifold to avoid damage during installation of the supercharger.



64. Remove protective tape from cylinder ports. Spray silicone lubricant or equivalent, onto the cylinder heads to help align the supercharger manifold.

NOTE: The supercharger manifold is very heavy. The following step should be performed with more than one person, an engine hoist, or equivalent.

Be careful not pinch the TMAP harness or break the manifold gaskets, as broken gasket debris can fall into the cylinder head ports.

65. Carefully lower the manifold onto the engine so that the bushings set properly onto the cylinder heads.

NOTE: Check to make sure there are no gaps between the gaskets and the manifold as well as the gaskets and the cylinder heads.

66. Secure the manifold using eight (8) supplied M6 x 45mm bolts in Bag #3. Using a 10mm socket with universal joint, tighten the bolts according to the torque sequence diagram below. Torque the bolts to 44 in/lb (5 Nm). Then re-torque in the same sequence to 89 in/lb (10 Nm).

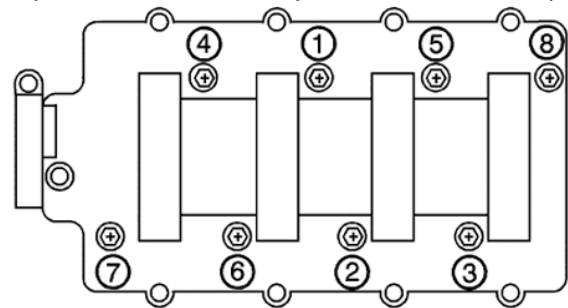

67. Remove and discard the factory installed metal clips on the supplied injectors as they will not be used.





Edelbrock Supercharger 2004-2007 GM Truck 4.8L, 5.3, 6.0L

Installation Instructions

68. Lightly lubricate the O-rings on the fuel rail fittings. On the passenger side rail, install one (1) straight fitting on the provision nearest to the bolt hole and the black plug on the opposite end as shown. On the driver side rail, install the 90° black anodized fitting onto the provision nearest to the bolt hole and the straight fitting on the opposite end as shown. Lubricate the all O-rings on the injectors and install them into the fuel rail so that the electrical connectors face away from the supercharger.



69. Install the supplied fuel cross-over hose onto the passenger side zinc 3/8" adapter and route it behind the manifold over towards the driver side. Make sure the cross-over hose routes behind the factory fuel supply line.



70. Lower the passenger fuel rail assembly onto the manifold lining up the injectors with their provisions on the manifold. Gently, push down on the rails until the injectors are fully seated. Secure fuel rail using a 5mm Hex tool and two (2) M6 x 12mm bolts from Bag #3.

71. Attach the fuel cross over to the driver side zinc 3/8" adapter and lower the driver side fuel rail assembly onto the manifold and line up the injectors with their provisions on the manifold. Gently, push down on the rails until the injectors are fully seated. Secure fuel rail using a 5mm Hex tool and two (2) m6 x 12mm bolts from Bag #3.

72. Install the supplied fuel line extension by inserting the male end into the main fuel supply line. Then connect the extension to the 90° black anodized fitting on the driver side fuel rail.

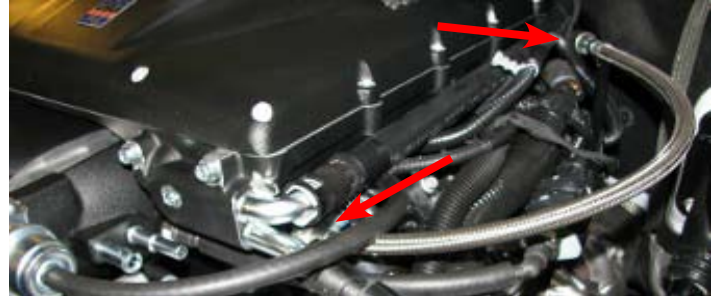

73. Connect the supplied injector harness adaptors to the injectors, then connect the injector harness adaptors to the factory fuel injector plugs.

74. Reinstall the coil pack assemblies using a 10mm socket and the factory bolts. Then plug in the main coil pack harnesses and the coil pack boots.

75. Remove both ambient air temp sensors from their mounting locations on the A-frame. Some vehicles are only equipped with one ambient air temp sensor.



76. Using a metal punch and provided drill bit, drill a new mount hole in the A-Frame support brace approximately 1-inch left of the accessory cooler mounting hole or the left ambient sensor location.

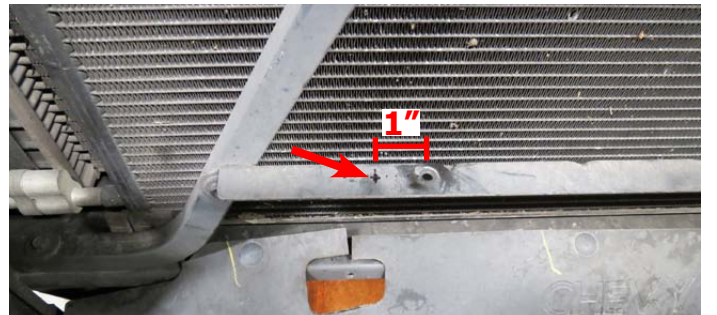



Edelbrock Supercharger 2004-2007 GM Truck 4.8L, 5.3, 6.0L

Installation Instructions

77. Using a 1-1/8" hole saw, create a hole on the inside of the radiator shroud, between the two shroud fins and approximately 1" from the front edge.

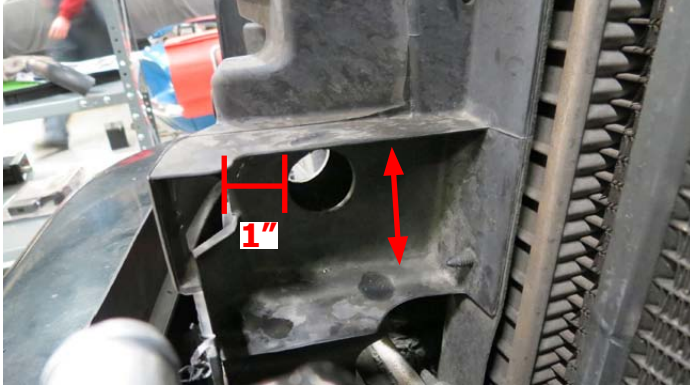

78. Secure the lower LTR brackets to the A-Frame with two (2) M6 x 16 bolts from bag #2.

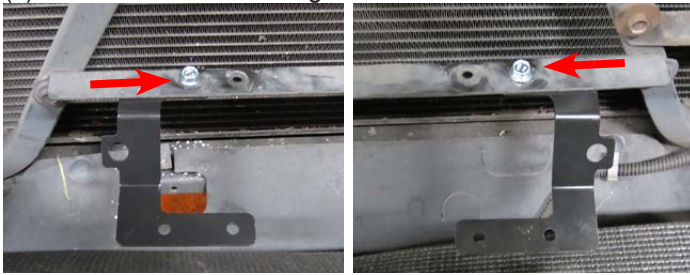

79. Using four (4) M6 x 10 bolts from bag #2, mount the lower LTR brackets to the lower LTR bungs ensuring that the inlet barb (passenger side barb) is in the up position once the LTR is installed.

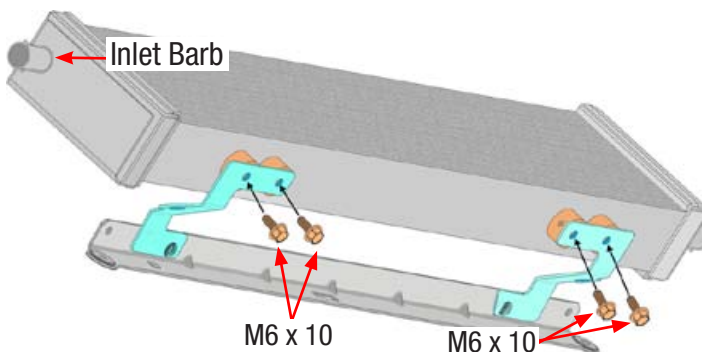

80. Secure the upper LTR bracket to the LTR with two (2) 1" spacers and two (2) M6 x 35mm bolts from hardware bag #2. Now secure the LTR to the hood latch location using two (2) M6 x 16 bolts along with two (2) M6 nuts.

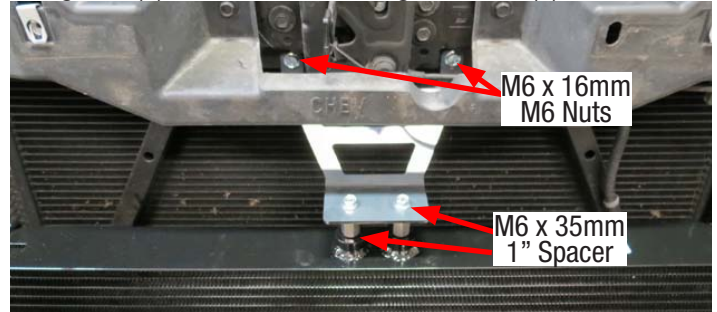

81. Secure both ambient air temp sensors onto the lower LTR brackets (one to each bracket).

NOTE: Vehicles equipped with one (1) ambient air temp sensor, mount to lower LTR bracket closest to sensor.

82. Remove two (2) bolts off the passenger side bumper support using a 15mm socket. **NOTE:** Location is just inside of the passenger wheel well liner, underneath the body mount.



83. Assemble the supplied water pump to the water pump bracket and bracket strap. Clock the water pump so that the outlet port (side port) is pointing up. Securely fasten the strap to the bracket with the supplied M8 x 30mm bolt in Bag #2. Now install the water pump assembly to the passenger side bumper support brace using the factory bolts.



Edelbrock Supercharger 2004-2007 GM Truck 4.8L, 5.3, 6.0L

Installation Instructions

NOTE: Vehicles with larger aftermarket wheels need to check wheel to water pump hose clearance. This must be performed once the water pump hoses are installed and before operating the vehicle. To properly check clearance, turn the wheel all the way to the left while the vehicle is on the ground. Visually inspect the wheel clearance. Water pump hoses can be secured away from the wheel if additional clearance is needed.



84. Route the LTR to Manifold Hose along the bottom of the lower radiator fan shroud and install onto the lower passenger side manifold inlet barb. Using four (4) wire ties, secure the hose to the lower radiator shroud.

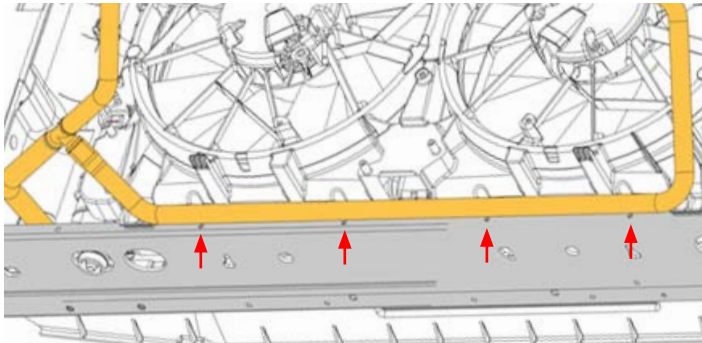

85. Install the other end of the LTR to Manifold hose onto the lower driver side manifold inlet barb.

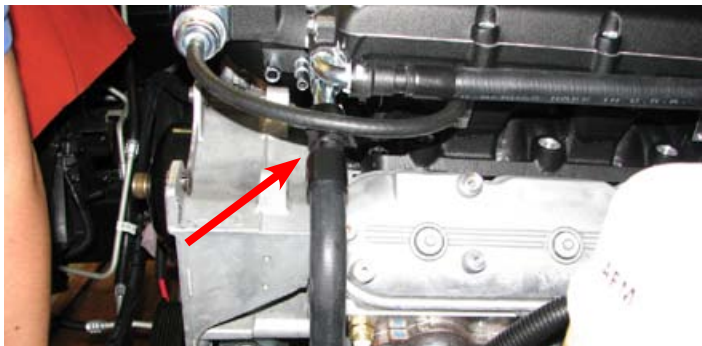

86. Now route the LTR to Manifold hose towards the LTR as shown below, and secure it to the LTR outlet barb using one (1) 3/4" hose clamp in Bag #2.

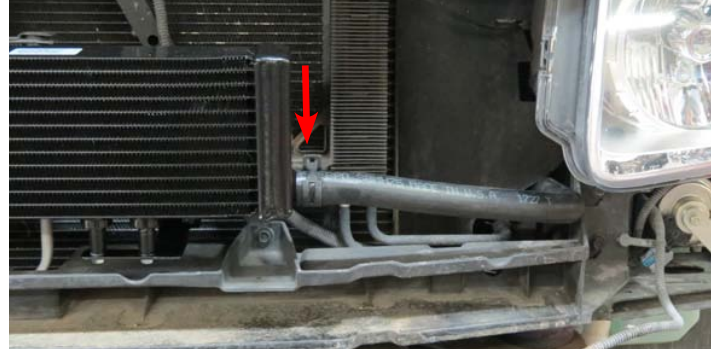

87. Install the Manifold to Recovery Tank hose onto the upper passenger side outlet barb on the manifold.



88. Then route the hose behind the manifold and install it onto the upper driver side manifold outlet barb.





Edelbrock Supercharger 2004-2007 GM Truck 4.8L, 5.3, 6.0L

Installation Instructions

89. Using a hose clamp tool or equivalent, install the water pump to LTR hose to the LTR inlet barb with one (1) 3/4" hose clamp from Bag #2. Now route the hose through the hole opening in the radiator shroud into the engine bay and down towards the water pump. Secure the hose to water pump using one (1) 3/4" hose clamp from Bag #2.



90. Using four (4) M6 x 16mm bolts from Bag #2, install the recovery tank bracket onto the recovery tank as shown.



91. Connect the Manifold to Recovery Tank hose to the recovery tank's inlet barb using one (1) 3/4" hose clamp. Connect the Tank to Water Pump hose to the tank's outlet barb and secure with one (1) 3/4" hose clamp. Route Tank to Water Pump hose down towards the water pump and secure to the water pump's inlet barb using one (1) 3/4" hose clamp.

92. Install the tank onto the two (2) front passenger side coil pack studs with two (2) M6 nuts from Bag #2.

NOTE: The oil or transmission dipstick location will vary depending on year and model. If the reservoir obstructs the dipstick, carefully bend the dipstick tube for clearance.

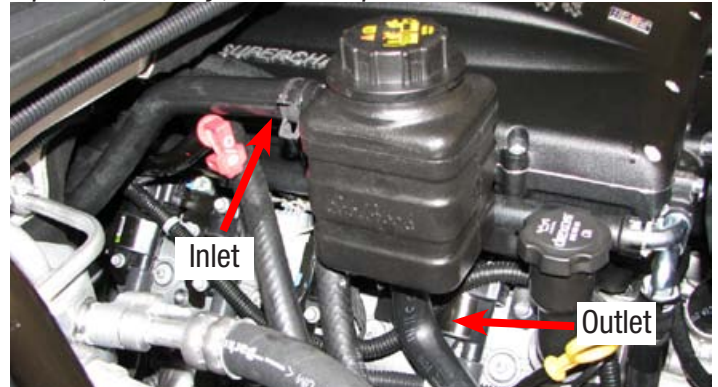

93. Install the supplied EVAP bracket onto the driver side coil pack assembly stud using one (1) M6 nut from Bag #2. Stud location is in between the first and second coil packs. Install the supplied EVAP solenoid onto the EVAP bracket as shown.

NOTE: For trucks equipped with return-style fuel systems. Secure the EVAP solenoid with the bracket included in the #15775 Supplemental Fuel System (sold separately).



94. Connect the rear EVAP hose previously installed (Step 47) to the rear barb on the EVAP. Install the front EVAP hose on the right rearmost barb of the manifold nose and connect it to the front barb of the solenoid. DO NOT connect the EVAP harness to the solenoid.





Edelbrock Supercharger 2004-2007 GM Truck 4.8L, 5.3, 6.0L

Installation Instructions

95. Using two (2) 1/2" hose clamps from Bag #2, install the provided brake booster vacuum hose to the brake booster check valve and to the first barb (closest to front) on the manifold nose. Reinstall the brake booster check valve harness (if applicable). If vehicle is not equipped with a brake booster hose, plug the front barb on the supercharger with the supplied plug.



96. Install the driver side PCV hose by sliding it onto the rear barb located on the driver side valve cover. Then install it on the center barb located on the manifold nose. Be sure to route the hose between the coil bracket and intercooler hose.

NOTE: On earlier trucks, there are no quick connect fittings on valve covers. Removal of the 90 degree quick connect fitting on the drivers side PCV hose may be necessary.



97. Using a 10mm socket, remove the factory throttle body from the intake manifold. Then carefully remove the throttle body gasket as it will be reused.

98. Install the factory throttle body gasket onto the supercharger throttle body flange as shown.



99. Using three (3) supplied M6 x 35mm bolts in Bag #1, install the factory throttle body onto the throttle body flange.



100. Install the passenger side PCV hose by sliding it onto the front barb located on the passenger side valve cover. Then install it on the barb located on the throttle body flange.

NOTE: On earlier trucks, there are no quick connect fittings on the valve covers. Removal of the straight quick connect fitting on the passenger side PCV hose may be necessary.

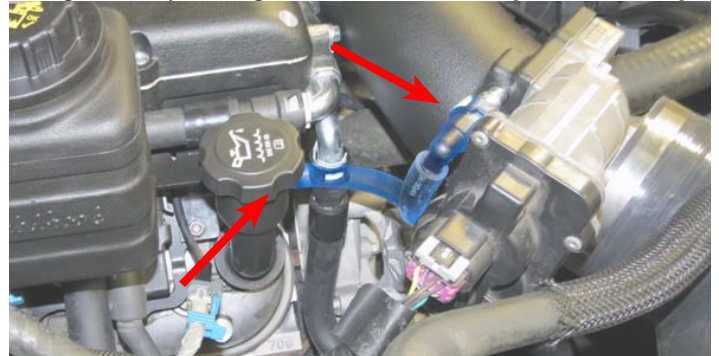



Edelbrock Supercharger 2004-2007 GM Truck 4.8L, 5.3, 6.0L

Installation Instructions

101. Route the previously installed coolant crossover hose towards the throttle body and attach it to the throttle body with the factory hose clamp. Secure this hose with the retaining clip on the upper radiator hose.



102. Trim 15" off of the factory passenger side coolant crossover hose and attach it to the throttle body using the factory hose clamp.



103. Using a Torx T25, remove the factory airbox cover.



104. Replace the factory air filter with the supplied Green reusable air filter.



105. Install the supplied silicone elbow onto the airbox cover. Loosely install the supplied worm clamps onto the silicone elbow as shown.

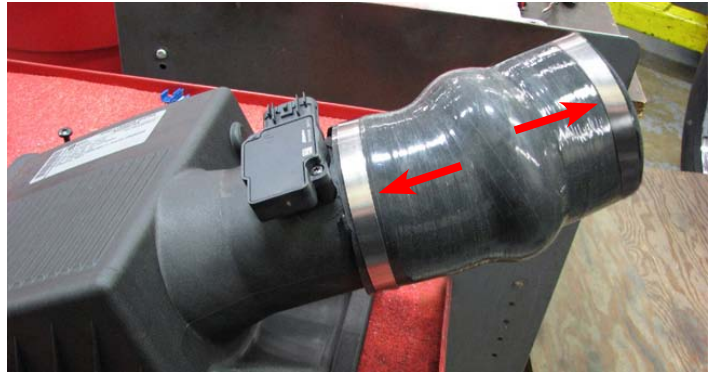

106. Reinstall the top cover by slipping the silicone elbow onto the throttle body first. Then secure the top cover using a Torx T25 and the factory airbox screws. Re-align elbow for best fitment and tighten both worm clamps.

107. Install the rubber grommet from bag #1 into the hole located in the upper cavity of the alternator bracket. Using a 15mm socket, install the alternator bracket with the factory alternator bolts. Route the actuator hose through the grommet as shown, and re-connect to the actuator.

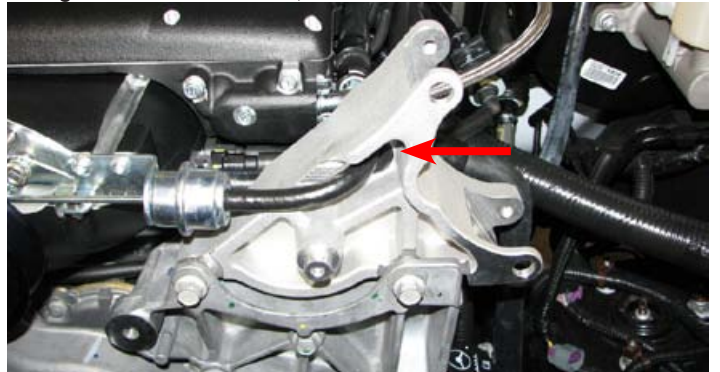



Edelbrock Supercharger 2004-2007 GM Truck 4.8L, 5.3, 6.0L

Installation Instructions

108. Remove the bolt, washer and bushing from the stock 90mm pulley and install them on the supplied 76mm pulley.



109. Apply Red Loctite to the threads on both idler pulley bolts. Then use a 15mm socket to install the 76mm idler pulley with the factory hardware to the left idler pulley location. Install the additional idler pulley to the right idler pulley location with one (1) M8 x 20mm bolt and one (1) M8 washer from Bag #1. Verify that both pulleys spin freely.

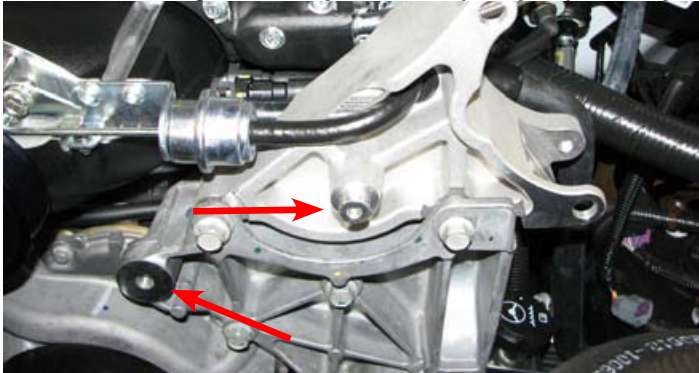

110. Using a 15mm socket and the supplied M10 x 90mm bolts in Bag #1, install the alternator onto the new alternator bracket and torque to 41 ft-lbs (55 Nm). Re-connect the alternator harness plug.

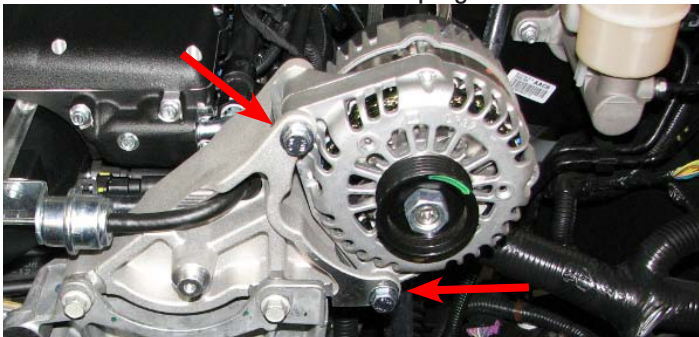

111. Route the supplied serpentine belt using the diagram below. Use a 15mm socket to release tension from the tensioner and re-tension after the belt is routed.

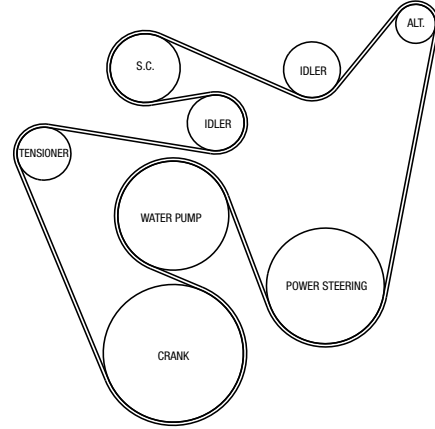

112. Connect the previously installed TMAP harness to the factory MAF sensor. Then connect the MAP connector to the factory MAP harness. Reconnect the throttle body harness to the throttle body.

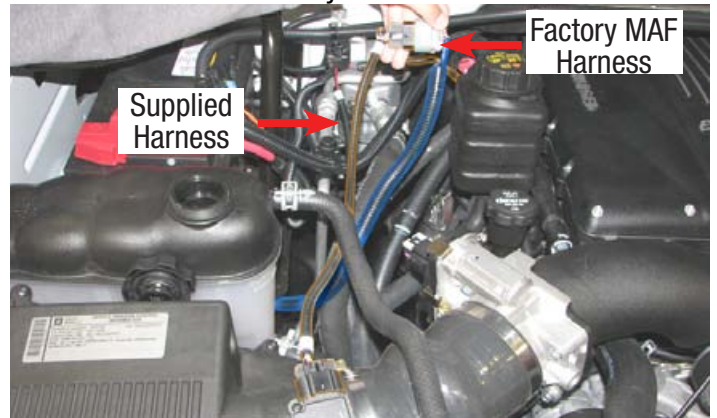

113. Mount the relay and the fuse holder on the water pump harness to the GROUND (-) located on the firewall. Connect the GROUND (-) wire on the water pump harness to the chassis ground on the firewall left of the relay mounting location.





Edelbrock Supercharger 2004-2007 GM Truck 4.8L, 5.3, 6.0L

Installation Instructions

114. Route the EVAP cable from the water pump harness along the top of the driver side fuel rail. Plug factory connector onto the female EVAP connector and the male connector to the EVAP solenoid.



115. Route the POSITIVE (+) lead on the water pump harness to the terminal junction right of the alternator mounting bracket and connect the power lead using a 14mm socket.

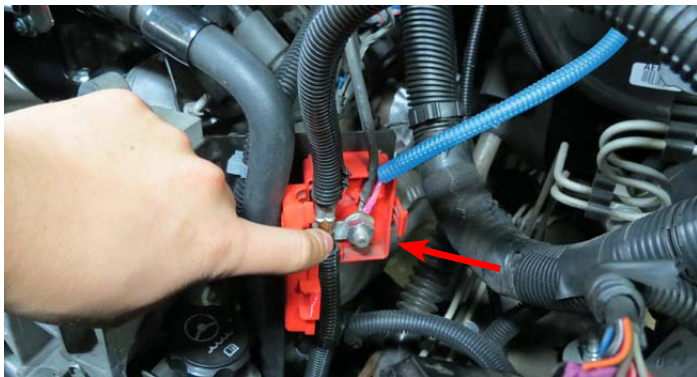

116. Route the water pump cable from the relay along the driver side intercooler hose. Then along the bottom of the radiator shroud to the pump. Connect the plug to the pump and secure the cable with wire ties onto the intercooler hose below the radiator.

117. Reinstall skid plate, front grill and upper radiator shroud.

118. Verify that the radiator petcock or the lower radiator hose is reinstalled and refill the coolant system as needed.

119. Fill the intercooler recovery tank with a 50/50 blend of water and coolant. Fill the tank until the coolant mixture level is roughly 1" from the top of the threaded neck.

120. Reinstall the negative terminal on the battery.

121. Turn the ignition key to the 'ON' position but **DO NOT START THE VEHICLE YET.**

122. Carefully inspect the fuel rail, fuel hose fittings and coolant hoses for any leaks. If any leaks are detected, shut the key off immediately and make any necessary repairs before continuing.

123. With the key in the "ON" position, verify that the coolant mixture is flowing briskly through the intercooler recovery tank, then install the cap. The intercooler pump will cycle and the water level may change. Repeat Step 104 as necessary until proper mixture level is reached.

124. Visually inspect the front passenger wheel to water pump hose clearance.

NOTE: Vehicles with larger aftermarket wheels need to check wheel to water pump hose clearance. This must be performed once the water pump hoses are installed and before operating the vehicle. To properly check clearance, turn the wheel all the way to the left while the vehicle is on the ground. Visually inspect the wheel clearance. Water pump hoses can be secured away from the wheel if additional clearance is needed.

125. Check all fluid levels before operating vehicle.

Congratulations on the installation of your new Edelbrock E-Force Supercharger System. If you have any questions, please call our **Technical Support hotline at 1-800-416-8628** and one of our technicians will be happy to assist you.