



PERFORMER RPM AIR-GAP AMC INTAKE MANIFOLDS
For 1967-1969 290-390 C.I.D. AMC - Part #7530
& 1970-1991 304-401 C.I.D. AMC - Part #7531
INSTALLATION INSTRUCTIONS

PLEASE study these instructions carefully before beginning this installation. Most installations can be accomplished with common tools and procedures. However, you should be familiar with and comfortable working on your vehicle. If you do not feel comfortable performing this installation, it is recommended to have the installation completed by a qualified mechanic. If you have any questions, please call our **Technical Hotline at: 1-800-416-8628**, 7:00 am - 5:00 pm, Pacific Standard Time, Monday through Friday.

IMPORTANT NOTE: Proper installation is the responsibility of the installer. Improper installation will void your warranty and may result in poor performance and engine or vehicle damage.

DESCRIPTION: Edelbrock Performer RPM Air-Gap manifolds are designed to provide performance increases in the 1500-6500 rpm range. The #7530 is designed for 1967-1969 AMC 290-390 c.i.d. engines. The #7531 is designed for 1970 & later 304-401 c.i.d. engines. On early engines, the intake manifold bolt holes are in-line. The block deck height is 9.175". On late engines, the two center bolt holes are .281" higher on the intake flange, and the deck height is 9.208". Late model heads and manifold may be installed on early blocks. However, this will cause a slight bolt and port misalignment. If your engine is mis-matched, the best solution is to select the intake manifold that matches the engine block, then drill the center bolt holes in the proper location using the gasket as a template.

• **KIT CONTENTS:**

- 1 PCV Baffle Plate
- 2 #8 x 3/8" Drive Screw
- 1 10-32 x 1/2" Hex Cap Screw
- 1 1/4" x 1/8" Sleeve
- 1 1/4" Star Washer
- 1 1/4" Shank, 3/16" Hole Shoulder Stud
- 1 1/16" x 1/2" Cotter Pin
- 1 PCV Grommet

• **ACCESSORIES & INSTALLATION ITEMS:** Major recommendations are listed below. See our catalog for details. **To order a catalog, call (800) FUN-TEAM**, or visit www.edelbrock.com.

• **EGR SYSTEMS:** These manifolds will not accept stock EGR (exhaust gas recirculation) equipment. EGR systems are used on most 1972 and later model vehicles. Check local laws for requirements.

• **GASKETS:** Do not use competition-style intake gaskets for this street manifold. Due to material deterioration over time, internal leakage of vacuum, oil, and coolant may occur. **NOTE: YOU MUST USE a factory metal valley tray gasket. If your stock valley tray is in good condition, it may be re-used.**

INTAKE MANIFOLD	REFERENCE	RECOMMENDED GASKET
7530, 7531	(None)	Stock or Stock Replacement (FEI-PRO MS96011)

- **CARBURETOR RECOMMENDATIONS:** See our catalog for details regarding parts required for installation.

CARBURETOR	CHOKE TYPE	PARTS REQUIRED FOR INSTALLATION
Thunder Series #1805 (650 CFM)	Manual	#8034 AMC Throttle Adapter ('79 and later)
Thunder Series #1806 (650 CFM)	Electric	#8034 AMC Throttle Adapter ('79 and later)
Thunder Series #1825 (650 CFM)	Manual	#8034 AMC Throttle Adapter ('79 and later)
Thunder Series #1826 (650 CFM)	Electric	#8034 AMC Throttle Adapter ('79 and later)
Performer Series #1407 (750 CFM)	Manual	#8034 AMC Throttle Adapter ('79 and later)
Performer Series #1412 (800 CFM)	Manual	#8034 AMC Throttle Adapter ('79 and later)
Performer Series #1413 (800 CFM)	Electric	#8034 AMC Throttle Adapter ('79 and later)
Thunder Series #1812 (800 CFM)	Manual	#8034 AMC Throttle Adapter ('79 and later)
Thunder Series #1813 (800 CFM)	Electric	#8034 AMC Throttle Adapter ('79 and later)

NOTES: Carburetor size (CFM) should be selected based on your specific engine combination. Consult your engine builder or contact our Technical Hotline at: 1-800-416-8628 for assistance. Carburetors require a #8008 or #8024 stud, washer and nut kit; determine proper length based on gasket thickness and your accessory mounting requirements (See catalog for details). If a manual choke Performer Series Carburetor is used and electric choke is desired later on, Performer Series carburetors can be converted to electric choke using Electric Choke Kit #1478. Manual choke Thunder Series carburetors CANNOT be converted to manual choke.

INSTALLATION PROCEDURE

- **PCV Baffle Plate:**

1. Install the PCV baffle plate using the supplied #8 x 3/8" drive pins (**See Figure 1**).

- **INSTALLATION:**

1. For proper PCV baffling; In addition to the supplied baffle, use OEM steel shim or FEL-PRO Part Number MS96011 intake manifold gasket for this installation.
2. Fully clean the cylinder head intake flanges and the engine block end seal surfaces.
3. We advise eliminating the end seals. Use RTV silicone gasket sealant instead. With NO SEALER applied, place gaskets in position, and position manifold on engine. Measure and record end seal clearance. Remove manifold and gaskets.
5. Due to restricted amount of metal separating this manifold's water inlet ports (left and right side port flange) and front/rear bolt holes, very little gasket purchase area exists. For a complete seal, lay a 1/4" bead of RTV silicone gasket sealant around water port and coat base bolt threads with RTV. Also, on the valley tray, apply a thin film of RTV around each intake port opening and along the bottom of the tray's intake flanges where the intake manifold will meet the tray. This procedure ensures a good seal.

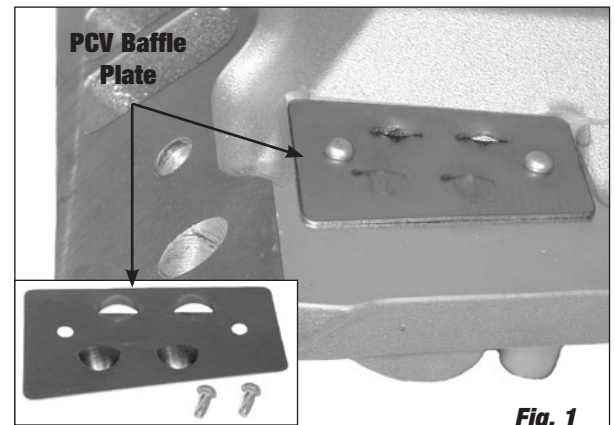

6. Apply a bead of sealant of the appropriate thickness (as measured earlier) across the block end seal surface, overlapping the intake gasket at the corners. This procedure eliminates end seal slippage and deterioration. Set manifold on engine.
7. Torque all of the manifold bolts in two steps by the sequence shown in **Figure 2** to 25 ft/lbs.

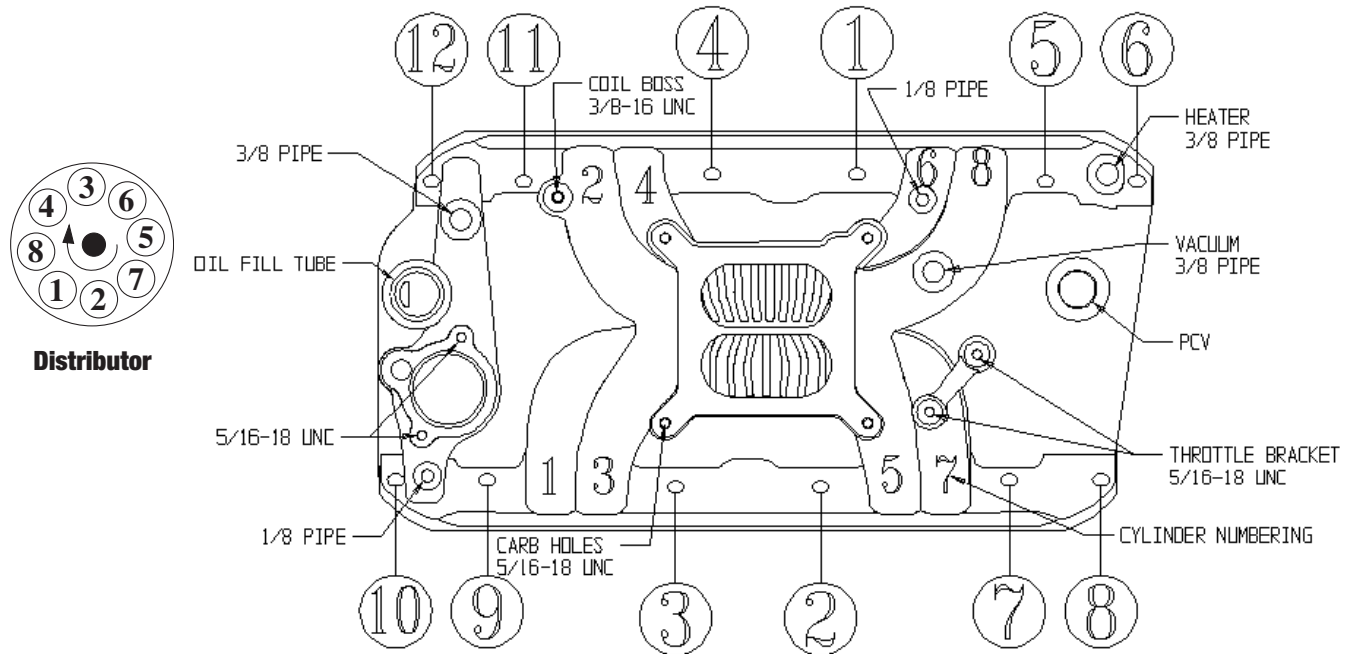
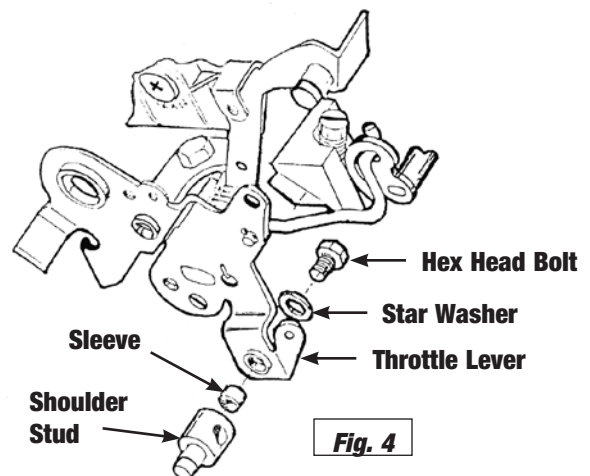
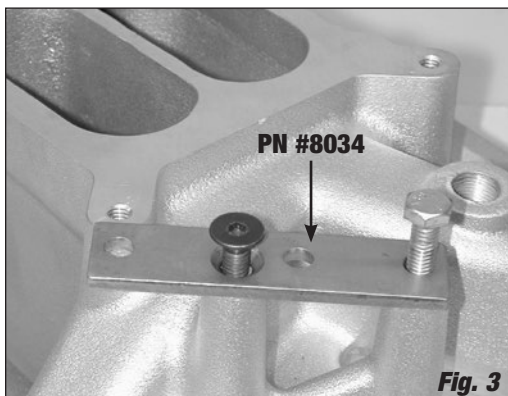

Figure 2 - 290-401 c.i.d. AMC Torque Sequence - Torque Bolts to 25 ft/lbs.
Firing Order: 1-8-4-3-6-5-7-2
Turn Distributor Counter-Clockwise to Advance Timing

- **THROTTLE & ACCESSORY BRACKETS:** Throttle and kick-down brackets on some vehicles may require modification to fit.
 1. Some vehicles with 4-bbl carburetors will require a throttle bracket extension plate to move the throttle bracket forward. This part is available as Edelbrock #8034 (**See Figure 3**).
 2. On vehicles equipped with an automatic transmission, a kick-down stud is required at the lower carburetor lever to operate the transmission kick down rod. This stud is supplied with each manifold and will bolt directly to Edelbrock Performer Series and Thunder Series carburetors (**See Figure 4**).



- **PCV VALVE:** Some engines use a PCV valve that is clamped to a hose between the carburetor and manifold. The stock AMC manifold has a 3/8" NPT pipe port at the manifold rather than a hole to accept a rubber grommet which the Edelbrock manifold uses. To re-install the PCV valve to our manifold, use the provided grommet and 10" of 3/8" vacuum hose (*See Figure 5*).

- **PREP AND TUNING FOR POWER:**

NOTE: Please refer to Edelbrock Performer Series Carburetor Owner's Manual for detailed tuning procedures.

1. Due to design, the fuel/air mixture and cylinder charging are very efficient with Performer manifolds. Generally speaking, the stock jetting for the recommended aftermarket carburetors will not need changing. Specific applications may show an increase in performance through further tuning.
2. Aftermarket distributor curve kits may be used with this intake manifold.
3. Use modified or high performance cylinder heads such as our Performer RPM AMC.
4. Installation of aftermarket headers, camshafts or both may lean carburetor calibration. Should this occur, recalibrate with a richer jet.

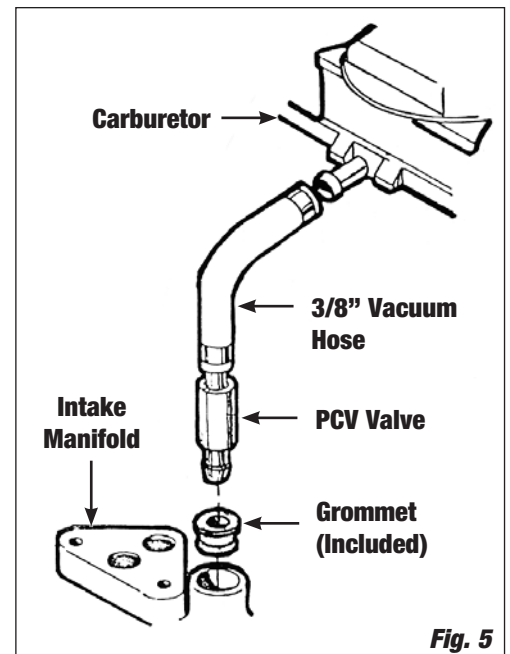

Fig. 5

- **CAMSHAFT AND HEADERS:** Performer manifolds are compatible with aftermarket camshafts and headers. Header primary tube diameter should be 1-5/8" to 1-3.4" depending on the specific engine combination. Edelbrock has developed a camshaft for use with this intake manifold on 343-401 c.i.d. engines; Performer RPM #7132. Please check the catalog or website for rpm and application guidelines.



Edelbrock, LLC • 2700 California St. • Torrance, CA 90503
Tech Line: 800-416-8628