

# **PATRIOT™**

## **Exhaust Products**

Corporate Office: PerTronix Inc. 440 E. Arrow Highway, San Dimas, California 91773 \* Phone 909.599.5955 \* FAX 909.599.6424 \* www.patriotexhaust.com

### **HEADER INSTALLATION INSTRUCTIONS**

#### **H8206 & H8206-1**

**MOPAR**

**67-82 A, B, E & F Bodies**



This product is Not legal for Street or Off Highway use in California or in states that have adopted California Emissions Regulations and is only intended for Closed Course Competition use, except 1965 and Older US manufactured California Certified vehicles, 1967 or older US manufactured Federally Certified vehicles, or 1967 and older Foreign manufactured vehicles which may have any aftermarket add-on or modified part installed as long as the vehicle can still meet the tailpipe emission standards for the year of the vehicle and retain any original or retrofit crankcase control (PCV) devices and NOx device required for the year of the vehicle.

**PerTronix®** thanks you for choosing **PATRIOT Exhaust Products**, the best value for the dollar of any brand in the industry. Please read and understand these instructions completely prior to starting work.

CHECK TO MAKE SURE YOU RECEIVED THE PROPER PARTS FOR YOUR APPLICATION. IF YOU ARE UNSURE YOU HAVE RECEIVED THE PROPER PARTS, CALL BEFORE YOU START WORK.

**BE SURE TO WORK SAFE!** WHENEVER YOU WORK UNDER THE VEHICLE BE SURE THAT IT IS LOCATED ON LEVEL, SOLID GROUND AND IS SUPPORTED BY ADEQUATE SAFETY STANDS!

**REMEMBER: HOT ASPHALT WILL NOT SUPPORT MOST JACK STANDS!**

Many factors affect the installation of headers, some of which are broken or aftermarket motor mounts, accidents that impact the configuration of the frame, and/or the installation of different engines or aftermarket cylinder heads. Most installations require some welding. If you are uncomfortable with welding operations, we recommend that you contact a professional exhaust system specialist to install your new headers.

**Attention Customers breaking in new engines:** Due to the extreme heat generated during the break-in process, the appearance of the ceramic coating may be altered in certain areas. The protection characteristics and thermal barrier properties of the coating is never compromised. It is recommended that a cast iron manifold or old set of headers be used for this process.

**Notice:** The coating of these headers can be marred or scratched during installation. If the header needs to be returned and is damaged, you will be charged for recoat.

### **DISASSEMBLY**

1. Disconnect the negative battery cable from the battery.
2. If a car lift is not available, raise the vehicle 2 feet or higher and support it with adequate safety stands. Make sure the vehicle is on a flat solid surface and is stable.
3. Apply penetrating oil to all nuts and bolts to be removed.
4. Remove and mark all spark plug wires and then remove all spark plugs.  
**NOTE:** Grasp the spark plug boot, not the wire, and use a twisting motion while pulling the wire from the plug.
5. Disconnect the head pipes from the exhaust manifolds.
6. Drain radiator (coolant may be reused if drained into a clean container).
7. Remove front and rear studs from head.

8. Remove the manifolds.
9. Remove studs from heads.
10. Remove clutch linkage (if manual transmission).
11. Remove the left side tie rod from the drag link.
12. Remove the drag link from the pitman arm.
13. Disconnect and remove starter.
14. Remove shift linkage and kick down linkage.
15. Remove the oil filter.
16. Remove engine to bellhousing brace (if so equipped).
17. Replace the spark plugs finger tight so debris will not get into the cylinders during the cleaning operation.
18. Remove any gasket material or any carbon deposits that remain on the head surface. The use of a gasket removal agent will ease the removal of any gasket material. We recommend the use of a sharp gasket scraper to remove the bulk of material and to finish the operation with a sanding block to provide a clean flat sealing surface.
19. After cleaning is complete remove the spark plugs again.
20. Note: Engines with smog heads but without smog pump must have the smog air holes plugged. Purchase (8) 1/4"-20 x 1/4" long allen head set screws. Thread holes with a 1/4"-20 tap. Make sure screw heads are flush with or below the exhaust port surface. See Figure A.

## ASSEMBLY

1. Apply a **THIN** film of Ultra Copper Hi-Temp Sensor-Safe Silicone Sealer to each side of the header flange gaskets around each of the exhaust port openings and let set up for a couple of minutes.
2. Stick the gaskets onto the headers. Small pieces of masking tape can be used to help hold the gasket to the header.
3. To prevent coolant leaks, apply a small amount of sealant (Ultra Copper Hi-Temp Sensor-Safe Silicone Sealer) to the header bolts supplied with the headers for all bolts that go into the water jackets.
4. Start the left header from below and work it up through the chassis into position over the exhaust ports. Start header bolts but leave header loose.
  - a. Note: Some vehicles will require raising the engine approximately 3" to install the headers. Remove center bolt from left motor mount and jack up engine approximately 2-3". Note: Be sure to use a board between oil pan and jack.
  - b. Note: On some models it may be necessary to remove the bolts holding the steering box so that it may be moved aside.
5. Lower engine and replace motor mount bolt.
6. Move the steering box back into place and replace the steering box bolts.
7. With the header still loose, replace the starter.
8. Reconnect drag link to pitman arm and tie rod to drag link.
9. Tighten all header bolts evenly to a final torque of approximately 35 ft. lbs.
10. Replace the clutch linkage (if manual transmission).
11. If automatic (with shift on column) modify the linkage according to Figure B & C and reinstall.
12. Replace kick down linkage.
13. Remove center bolt from right motor mount and jack up engine approximately 3". Note: Be sure to use a board between oil pan and jack.

14. Start the right header from below and work it up through the chassis into position over the exhaust ports. Start header bolts.
15. Lower engine and replace motor mount bolt.
16. Replace oil filter.
17. Double check that all steering linkage is in place and tightened properly.
18. Tighten all the header bolts evenly to a final torque of approximately 35 ft. lbs.
19. Replace the spark plugs. When you install the spark plugs, apply a **small** amount of anti-seize to the threads.
20. Check the clearance between pipe (R-2) and the idler arm. It must be ¼" or more. If not, replace the motor mounts.
21. Make sure coolant drain is closed and refill the radiator.
22. Use the supplied reducers to connect the collectors to your stock exhaust system.
23. Connect the negative battery cable.
24. Check over the installation to make sure that all wires, lines, hoses. etc. are connected and have adequate clearance to protect them from the heat generated by the headers.

## START THE ENGINE

Start the engine and allow it to warm up to operating temperature. Check for any unusual noises, liquid leaks or exhaust leaks. If everything is OK, stop the engine and tighten all bolts while the engine is still warm.

**NOTE:** Check the bolts periodically to make sure they have not loosened. Re-tighten after the first 500 miles and then again at 1000 miles.

## IMPORTANT CHECK LIST

- **Be sure that all brake lines and fuel lines are clear of headers and/or connector pipes.**
- **All spark plug wires, battery cables, or other electrical components should be clear of headers and/or connector pipes.**
- **If dipstick tube was removed, make sure it is installed properly and that the dipstick has been replaced.**
- **Double-check the tightness of all bolts including brackets and accessories.**

## PARTS LIST

<u>Qty</u>	<u>Description</u>
1	Left side header
1	Right side header
2	Reducers
2	Header gaskets
2	3" flat gaskets
12	5/16"-18 x 3/4" header bolts
6	3/8"-16 x 1" hex head cap screws
6	3/8"-16 hex nuts

## Figure A

### HEAD & EXHAUST PORTS

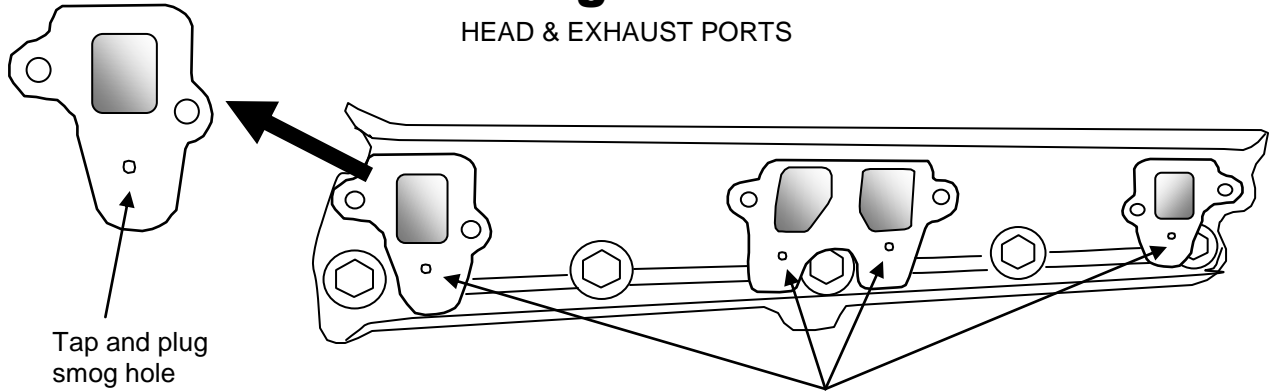

Tap and plug  
smog hole

Tap smog holes with  $\frac{1}{4}$ "-20 tap. Use  $\frac{1}{4}$ "-20 x  $\frac{1}{4}$ " long allen set-screws to plug the tapped holes. Make sure the screws are flush with or below the exhaust port surface.

## Figure B

### AUTOMATIC, COLUMN SHIFT TRANSMISSION SHIFT LINKAGE

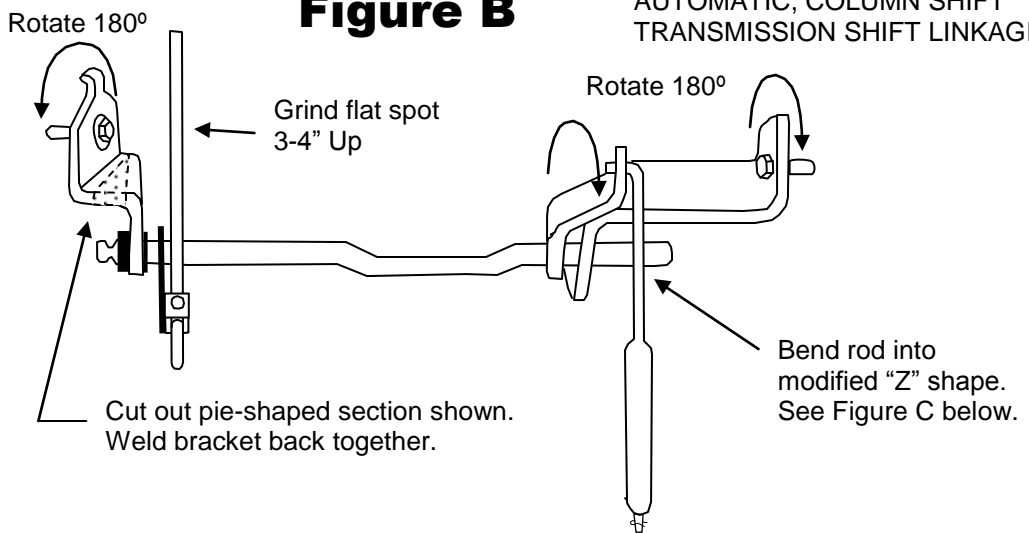

## Figure C

### AUTOMATIC, COLUMN SHIFT TRANSMISSION SHIFT LINKAGE

