



1826 Baldwin St. – Rockledge, FL 32955
Ph: (321) 632-6205 Fax: (321) 632-0247
www.racewithjw.com

“Ultra-Bell” P/N 92450, 92451, 92452, and 92453-164AOD Preparation and Assembly

This Ultra-Bell will accommodate most GM 10” and smaller torque converters.

It is suggested to have these procedures performed by a skilled machine shop and/or transmission shop. However with a little time and patience can be easily done with basic hand/power tools.

Prepare the transmission as suggested in Figure 1.

To prepare the transmission for Ultra-Bell assembly using the “Sawz-all” method, transmission should be inverted as shown. Remove the bellhousing leaving enough material to finish with a grinder. NOTE: It is not necessary to remove the front pump during this stage, however it is necessary to cover all transmission openings. **DO NOT ALLOW ANY METAL SHAVINGS TO ENTER THE TRANSMISSION.**

DO NOT CUT INTO THE PAN RAIL. Remove casting tabs located a 12, 4, and 8 O'clock positions for TH350 and TH400 applications.

Note: this operation may also be performed on a milling machine.

The finished dimensions taken from the rear housing surface will be:

PG: 9 13/16”	TH400: 17 5/8” (remove tabs)
TH350: 15 1/8” (remove tabs)	AOD: 14 3/4”

CAUTION: Dimensions may vary with your transmission Case:

Rough Cut Dimensions:

- PG: 10”
- TH350: 15 1/4”
- TH400: 17 3/4”
- AOD: 14 7/8”

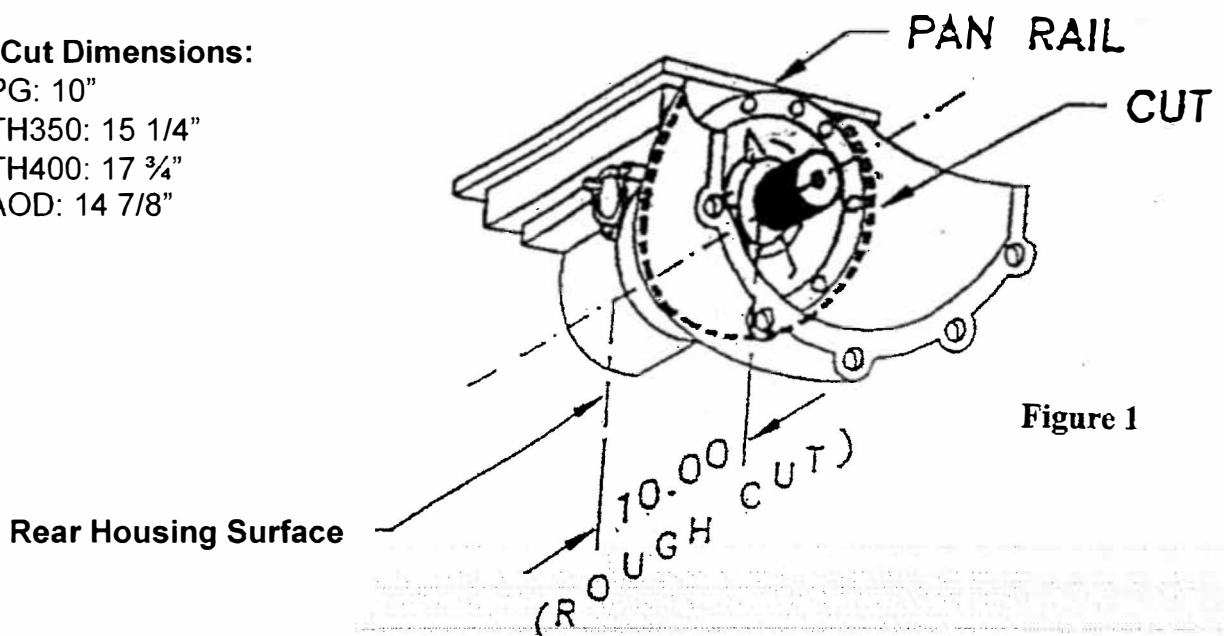



1826 Baldwin St. - Rockledge, FL 32955
Ph: (321) 632-6205 Fax: (321) 632-0247
www.racewithjw.com

Prepare transmission case and attach bellhousing as indicated in Figure 2.

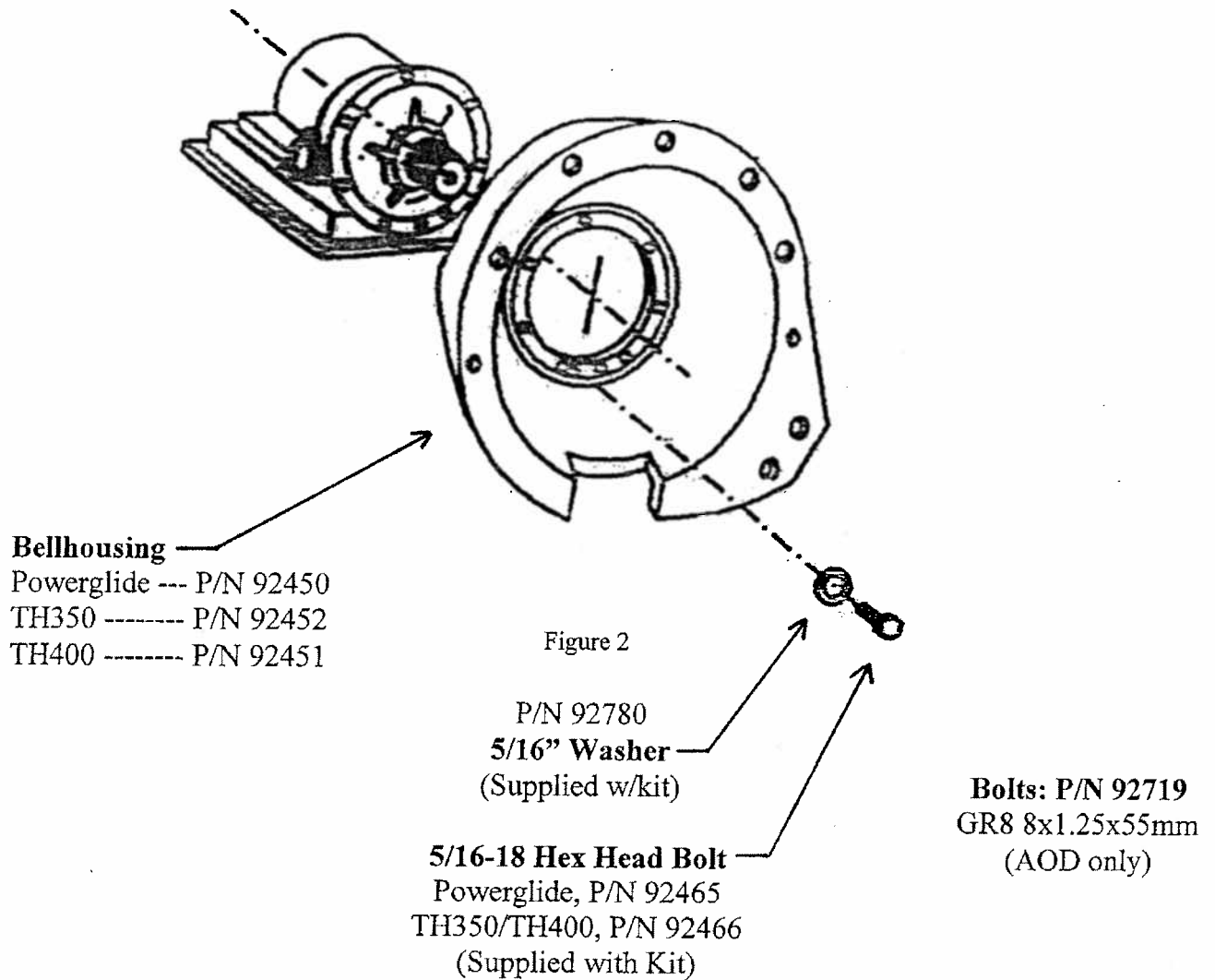

Use Bolt Kit # 92465-A to mount the assembly to the transmission for AOD applications.
Use Bolt Kit #92467 to mount the the assembly to the engine.

NOTE: Install the Ultra-Bell using the bolts and washers provided. Also be sure to use the supplied O-Rings between the bellhousing and front pump mounting surface. **The Ultra-Bell should sit flush to the pump surface and not come in contact with the transmission case.** A small amount of sealant should be applied to the washers. Apply Red "Loctite" to the threads of the bolts and torque to 18ft/lbs.

J.W. Performance Releases Guidelines for Product Modifications on "Ultra-Bell" and "Ultra-Case" Recertification

J.W. Performance Transmissions releases acceptable modifications for SFI "Ultra-Bell" to racers. A complete guide is available from J.W. Performance direct, NHRA Division offices and Tech Directors, IHRA Technical Services, racers support services, and the Safety Foundation, Inc. These modifications pertain to acceptable drilling for lifting handle on "Ultra-Bell", transmission shield long strap and dipstick tube retention.

The "Ultra-Case" and "Ultra-Bell" are the only products that may be recertified factory direct or at the J.W. Performance racer support display trailer. The products **MUST** be removed from the vehicle for recertification and inspection.

Included in the guide is information pertaining to our contingency program guidelines to assist racers in collecting their contingency awards. A copy of the guide may be available by visiting the **Adventure Team Racing** or **J.W. Performance Racer Support** trailers, **J.W. Performance** direct at 321-632-6205



J. W. Performance Transmission, Inc. • 1826 Baldwin Street
Rockledge, FL 32955
Product info: 321-632-6205, ext. 3

S.F.I. ULTRA-BELL MODIFICATIONS HANDLE ATTACHMENT HOLES

- DO NOT DRILL, MODIFY OR COVER S.F.I. DECAL UNDER ANY CIRCUMSTANCE.
- TO MAINTAIN S.F.I. CERTIFICATION, MODIFICATIONS ARE ALLOWED IN THE SHADED AREA ONLY.
- FOUR (4) HOLES MAXIMUM. .250-.312 DIAMETER-THREAD INSERTS ALLOWED.

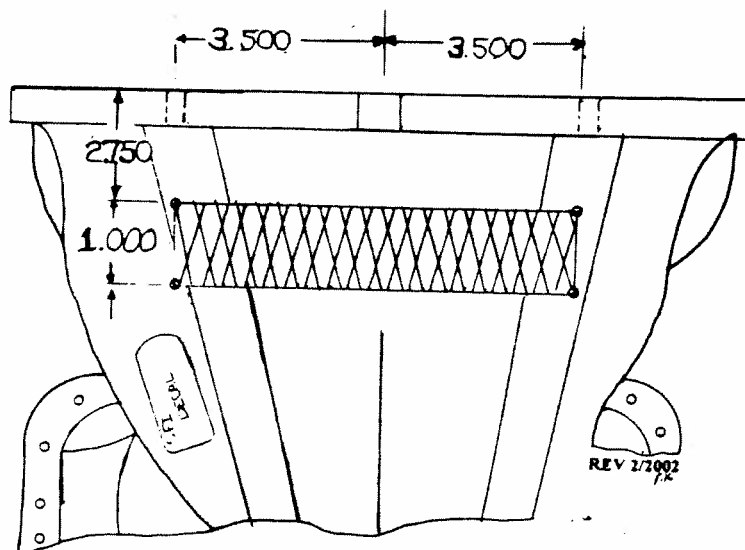

**S.F.I. ULTRA-BELL MODIFICATIONS
STOCK G. M. CASES REQUIRING A
TRANSMISSION SHIELD**

- DRILL ONE (1) HOLE .250-.312 (MIN.-MAX.) DIAMETER IN THE AREA INDICATED FOR RETENTION OF TRANSMISSION SHIELD LONG STRAP.
- THREAD INSERT ALLOWABLE

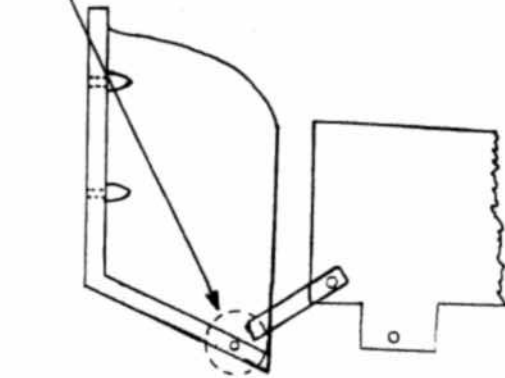

SFI BOLT HOLE- WITH USE OF TRANSMISSION SHIELD

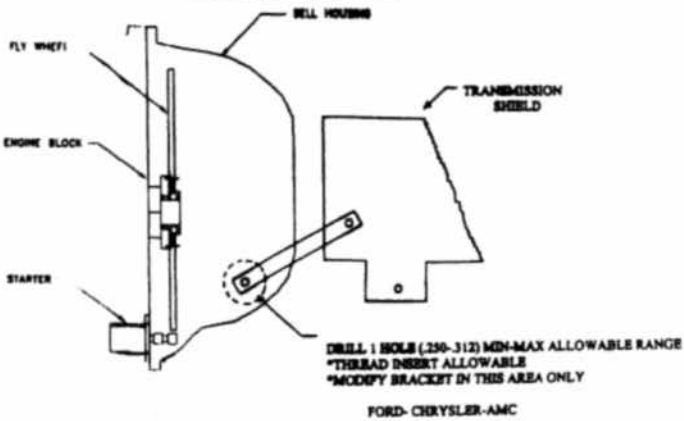

J.W.

PERFORMANCE TRANSMISSIONS INC.

S.F.I ULTRA -BELL MODIFICATIONS

- ULTRA-BELL MAY BE DRILLED IN LOCATION INDICATED FOR RETENTION OF DIPSTICK TUBE. [LONG OR SHORT DIP STICK]
- ONE HOLE ALLOWABLE (.250-.312 MIN.-MAX.)
- THREAD INSERT IS ALLOWABLE

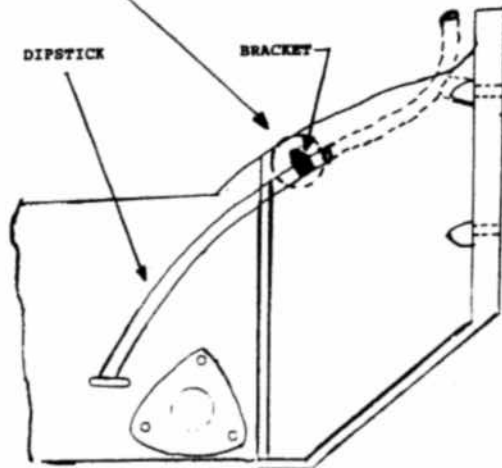

**S.F.I. ULTRA BELL MODIFICATIONS
UPPER MOUNTING HOLES**

THE TWO EARS THAT ARE SHADED MAY BE CUT OFF FROM THE ULTRA-BELL FOR CLEARANCE.

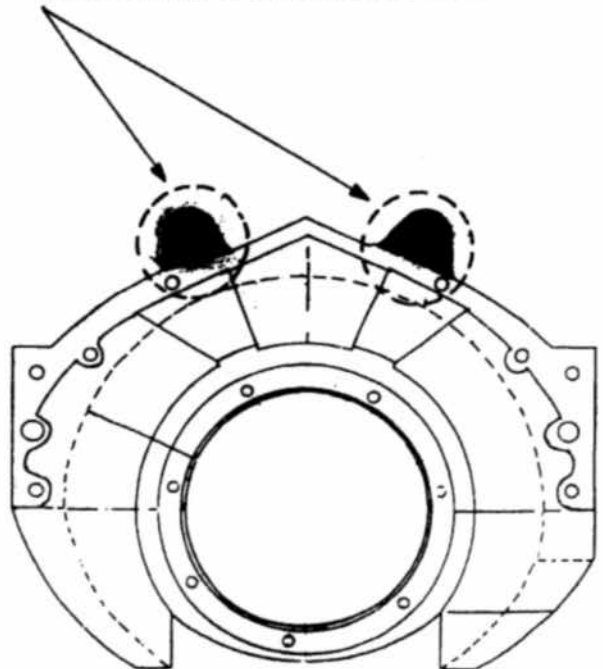



1826 Baldwin St. - Rockledge, FL 32955
Ph: (321) 632-6205 Fax: (321) 632-0247
www.racewithjw.com

Ultra-Bell O-Ring Locations

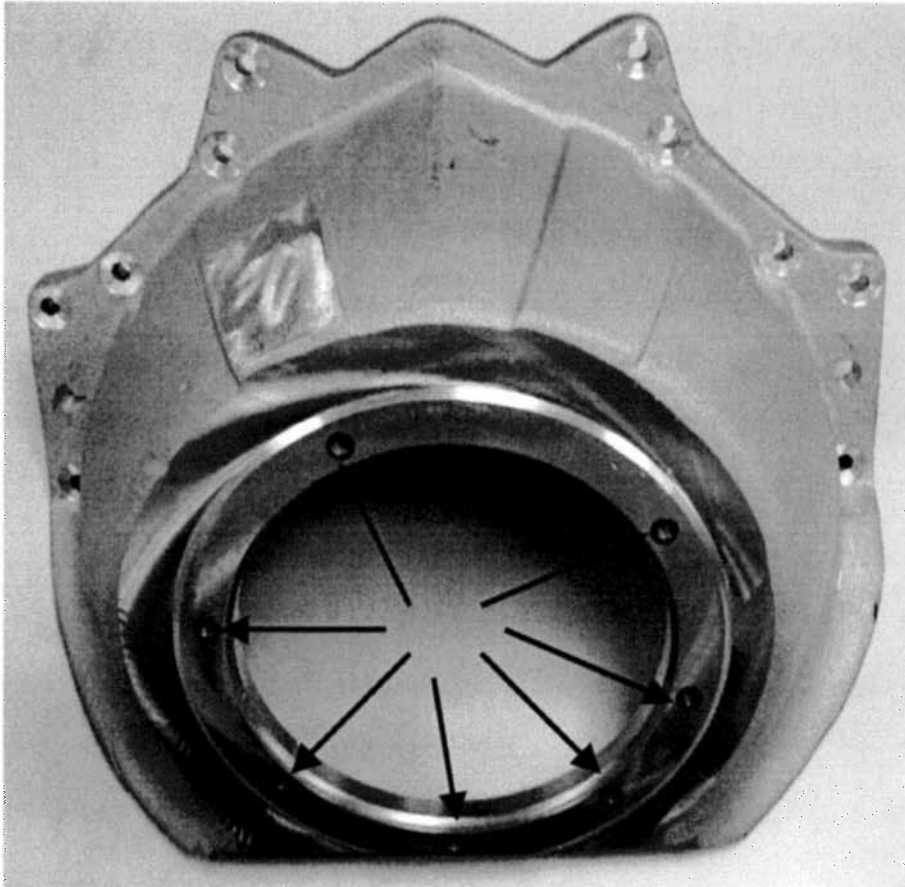

Place O-rings in machined pockets on transmission side of Ultra-Bell as shown.

Hold O-rings in place with a dab of transgel. Bolt the Ultra-Bell to the case per instructions.

92450: 7 O-rings
92451 and 92452: 8 O-Rings