



2501 Ludelle Street  
Fort Worth, Texas 76105  
817-244-6898 phone  
817-244-4024 fax  
800-423-9696 orders

E-Mail: [painless@painlessperformance.com](mailto:painless@painlessperformance.com)  
WebSite: <http://www.painlesswiring.com>

# 30708

## '67-72 GM Truck

### COURTESY LIGHT KIT

### INSTALLATION INSTRUCTIONS

THIS KIT CONTAINS TWO (2) LIGHT SOCKET ASSEMBLIES WHICH ARE DESIGNED TO MOUNT UNDER THE DASH AND PLUG INTO THE PIGTAIL, COMING OUT OF THE BOTTOM OF THE FUSEBLOCK, FOR ILLUMINATION OF THE FRONT SEAT FLOOR AREA OF INTERIOR.

**A.** MOUNT THE PLASTIC LIGHT HOUSINGS IN THE LOWER ROLL OF THE DASH OR KICK PANEL USING THE DRILL SCREWS PROVIDED. THE SCREWS GO THROUGH THE HOLE MOLDED INTO THE PLASTIC.

**B.** PLUG THE LARGER FEMALE BLACK CONNECTOR ON TO THE BLACK MALE CONNECTOR COMING OUT OF THE BOTTOM OF THE FUSE BLOCK. THIS CONNECTOR SHOULD ALSO HAVE ORANGE AND WHITE WIRES WHICH WILL MATCH THE WIRES IN THIS KIT.

**NOTE:** THE WHITE WIRE IS ATTACHED TO YOUR DOME LIGHT GROUND AND GOES TO THE LIGHT SWITCH DOME LIGHT GROUND TERMINAL ON THE HEADLIGHT SWITCH AND/OR THE DOORJAMB SWITCH. THE ORANGE WIRE IS THE POWER WIRE.

**C.** IF YOU PLAN TO USE THE JAMB SWITCHES PROVIDED, FIND A SUITABLE LOCATION THAT MAY BE ACCESSED FROM THE REAR IN THE DOOR PILLAR AND DRILL A 1/4" HOLE AND TAP THE HOLE FOR A 5/16" STANDARD THREAD. SCREW THE JAMB SWITCHES INTO THE DOORJAMB AND PLUG IN THE WHITE WIRE HARNESS.

**NOTE:** IF YOU ARE USING THE DOOR JAMB SWITCHES, PLUG IN THE REMAINING WHITE WIRE HARNESS ON TO THE REMAINING MALE PLUG OF THE ORANGE AND WHITE LIGHT HARNESS. THE BULLET CONNECTORS ON THE WHITE WIRE HARNESS PLUG INTO THE BACK OF THE JAMB SWITCHES.

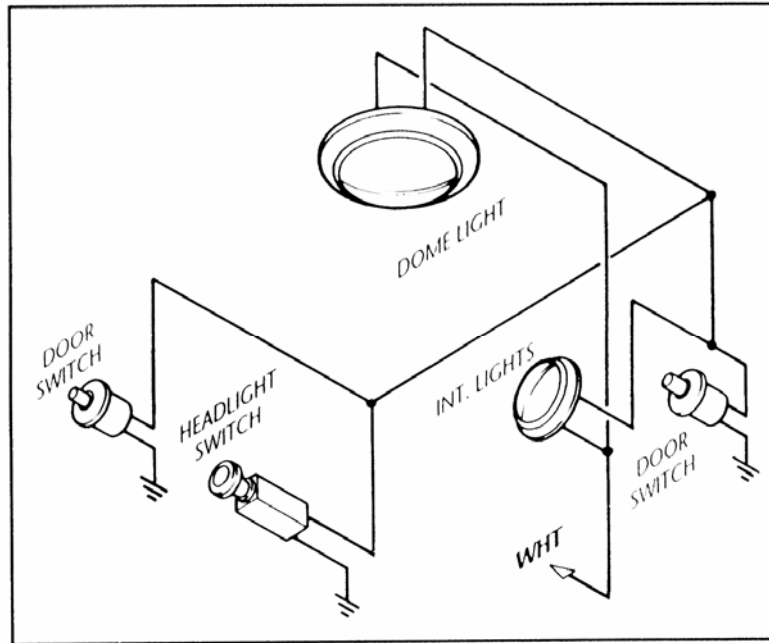

## **Painless Performance Limited Warranty and Return Policy**

Chassis harnesses and fuel injection harnesses are covered under a lifetime warranty. All other products manufactured and/or sold by Painless Performance are warranted to the original purchaser to be free from defects in material and workmanship under normal use. Painless Performance will repair or replace defective products without charge during the first 12 months from the purchase date. No products will be considered for warranty without a copy of the purchase receipt showing the sellers name, address and date of purchase. You must return the product to the dealer you purchased it from to initiate warranty procedures.

**Copyright © 2007 by Perfect Performance Products, LLC**